

CATALOGUE 2020

A man in a dark polo shirt and khaki pants is walking from left to right, carrying two blue crates filled with fresh produce. He is in a modern, industrial-style building with large green concrete pillars. In the background, a white delivery van with its rear door open is visible, showing more crates inside. The scene is brightly lit, suggesting an outdoor or well-lit indoor space.

COOLING SOLUTIONS FOR MOBILE DELIVERY

TEMPERATURE-CONTROLLED TRANSPORT AND STORAGE

Mobile living made easy.

 **DOMETIC**



ONE-DEGREE ACCURACY

CUSTOMISED COOLING SOLUTIONS FOR TEMPERATURE-CONTROLLED TRANSPORT

Taking highly perishable goods safely from one place to another – no problem with mobile refrigeration by Dometic. Our portable coolers have stood and passed the test of practice millions of times. To meet your demanding logistics needs they are fitted with special, high-performance electronics. Whatever it is you are transporting – lab samples, veterinary samples or specimens, temperature-sensitive medicines or perishable food – Dometic products provide one-degree accuracy for your freight!

- All products have been developed in compliance with the strict guidelines of HACCP and GDP.
- All Dometic production plants are certified according to ISO 9001, ISO 14001 as well as the EU Eco-Management and Audit Scheme.
- As an EMAS-certified company, we publish all environmental results as part of the Dometic Environmental Product Declaration.



DOMETIC ON THE WEB

Here's where you can find the complete Dometic range, with detailed information about all products. Plus, interesting facts about our company and download links for all our catalogues.

[dometic.com](https://www.dometic.com)



COOLBOXES

Insulated coolers for food transportation. Precise cooling for temperature-controlled transport. Customer-specific equipment with accessories.

PAGE 10 – 31



COOLING CONTAINERS

Top loaders and front loaders with one or two factory-set fixed temperature(s). Practical equipment details for convenient handling on the road and on site.

PAGE 34 – 43



MILK- & BEVERAGE COOLERS

Space-saving milk coolers for coffee machines. Beverage refrigerator for bars. Solutions for storing and serving wine.

PAGE 56 – 57



INTEGRATED COOLING

Fully integrated cooling systems for fitting refrigerated vehicles. Modular system, high-precision cooling with no roof-mounted parts.

PAGE 60 – 67



MEDICINE AND LABS

From stationary medical refrigerators to fitted equipment for ambulances and veterinary vehicles. High-precision temperature management, up-to-date documentation, convenient handling.

PAGE 46 – 53



COOLING UNITS

No space to spare for a fridge or cool box? Use our cooling units and evaporators to convert unutilised storage space into a customised refrigeration solution!

PAGE 70 – 79

INTRODUCTION

Cooling technology for temperature-controlled transport **6 – 9**

COOLBOXES

Passive coolboxes **12 – 15**
 Thermoelectric coolboxes and extra modules **16 – 21**
 Compressor coolboxes and extra modules **22 – 31**

COOLING CONTAINERS

Top loaders and front loaders **34 – 42**
 Extra modules **43**

MEDICINE AND LABS

Medical refrigerators **46 – 49**
 Stainless steel built-in cabinets for vehicles **50 – 51**
 Custom solutions for ambulances and veterinary vehicles **52 – 53**

MILK & BEVERAGE COOLERS

Milk coolers **56 – 57**
 Beverage refrigerator **57**

INTEGRATED COOLING

Modular components for fitting refrigerated vehicles **60 – 67**

COOLING UNITS

Coldmachine Series 50 **72 – 73**
 Coldmachine Series 80 **74 – 76**
 Coldmachine Series 90 **77 – 79**

THE RIGHT TEMPERATURE

KEY TO YOUR SUCCESS

“COOL” IS A VERSATILE WORD ...

It can range from $-22\text{ }^{\circ}\text{C}$ to $+65\text{ }^{\circ}\text{C}$, depending on the ambient temperature and on whatever is being transported. But for any product, the following applies: The key to success of perfect storage is constant temperature. You know the right temperature for your product. Dometic builds the ideal cooler for you. The temperature is factory-set and maintained at precisely $\pm 2\text{ }^{\circ}\text{C}$, which can be even more precise, if required. Of course, we can also set two fixed temperatures or just leave it to you to select the temperature. Or install a heater as an additional safety mechanism. Or equip the cooler with a data logger to allow you to demonstrate that the required temperature is maintained during transportation. The possibilities are endless so get in touch with us.



HACCP – DOMETIC FILLS THE GAPS IN THE COLD CHAIN

HACCP stands for Hazard Analysis Critical Control Points, an internationally binding quality management system for food products. The principle behind it is that all critical points in the delivery chain “from the stable to the table” are closely examined on the spot. For all critical points, limiting values are defined and then

continuously checked and documented. Critical risks are always involved when perishable food is exposed to high temperatures, e.g. while shopping or delivering to a customer. Investing in a refrigerated truck is not always financially viable. Why not save money and gain flexibility with mobile refrigeration by Dometic?

HACCP AND GDP MANAGEMENT

WITH CUSTOMISED COOLING SOLUTIONS FROM DOMETIC

FOR A SAFE AND PROFITABLE BUSINESS

Compliance with legal requirements not only means satisfied customers but also more profit. Success comes from within. When introducing an HACCP or GDP management concept, all work processes are put to the test. The decisive factor is the health risk for the consumer, but other deficiencies also come to light in the process. As a result, processes are tightened up, losses are minimised and resources are used more effectively.

HACCP – EVERY DAY WITH DOMETIC

1. **H**azard **A**nalysis: Analysing the risks to consumer health
2. **C**ritical **C**ontrol **P**oints: Tracing critical points in the cold chain
3. Defining the critical limits: What needs to be transported, when and at which temperature?
4. Safety precautions: Integrating coolers in the cold chain
5. Fine adjustment: Which type of refrigeration for which product? Any special designs needed?
6. Documentation: Not compulsory but advisable – and easy with Dometic!

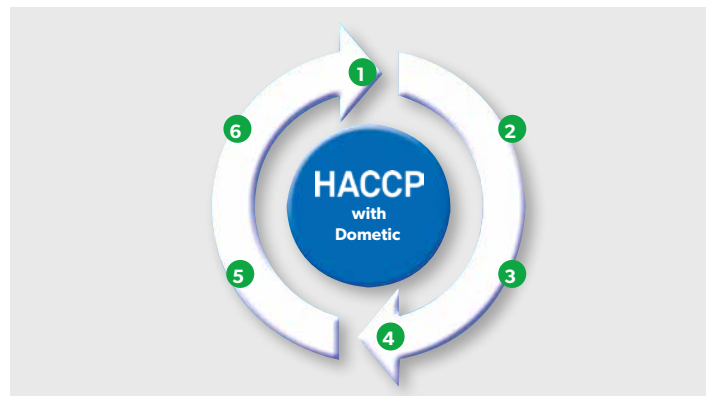

HACCP: A CONTINUOUS COLD CHAIN FOR PERISHABLE FOOD

Safety has priority when transporting temperature-sensitive goods. Responsible logistics providers thus comply with HACCP regulations and equip and certify their vehicles accordingly.

HACCP: Continuous cooling chain for perishable cooked food and produce



GDP: GOOD DISTRIBUTION PRACTICE FOR SENSITIVE MEDICINES

The EU's Good Distribution Practice (GDP) has made the requirements on transporting medicines more stringent. For especially sensitive products, the guideline requires operators to show that the required temperature is present along the entire length of the cold chain – even given extreme ambient temperatures. Data loggers etc. are used to prove adherence to temperature demands.



TAILOR-MADE REFRIGERATION SOLUTIONS

FOR MEDICINES, VACCINES, LAB SAMPLES AND MORE

Especially stringent requirements apply for the transportation and storage of blood donations, vaccines, lab samples, living organs and temperature-sensitive drugs. To ensure maximum safety for consumers, the EU's Good Distribution Practice (GDP) directive requires temperature management accurate to a single degree, as well as continuous documentation of the temperature curve.

Dometic's cooling solutions for mobile delivery catalogue gives you a cross-section of individual logistics solutions which we have developed for our customers over the past decades – from customer-specific portable coolers to high-quality built-in devices for ambulances, labs, doctor's surgeries and nursing homes. You can also use our cooling units to turn unutilised niches into your own customised cooling solution.

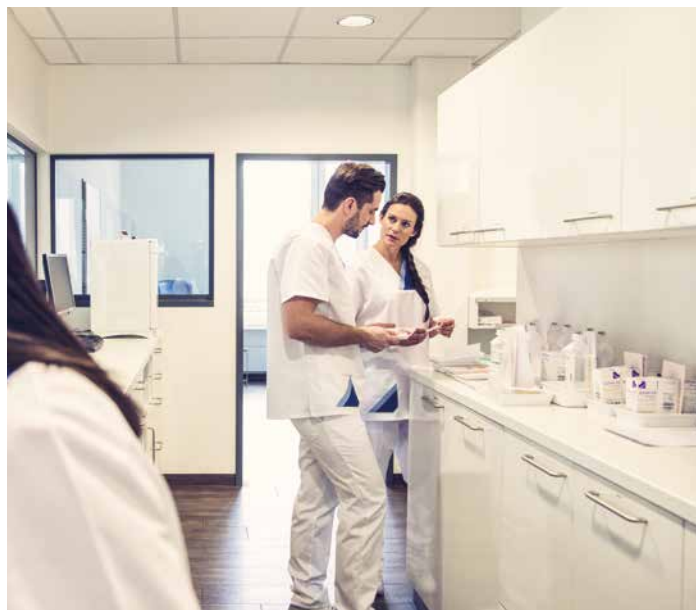

SPECIAL SOLUTIONS FOR MEDICAL TRANSPORTS, HUMAN AND VETERINARY MEDICINE

- Thermoelectric and compressor cooling and heat-retaining boxes with factory pre-set fixed temperature and customer-specific accessories (page 16 – 31)
- Refrigeration and deep-freeze containers as top loaders and front loaders with customer-specific equipment (page 34 – 43)
- Refrigerated medicine cabinets for on-site storage (page 46 – 49)
- Built-in stainless steel cabinets with compressor cooling or heating (page 50 – 51)
- Thermoelectric built-in cooler and warmer boxes for ambulances (page 52)
- Compressor cooler drawer for veterinary vehicles (page 53)
- Cooling units and evaporators for converting unused storage space into customised cooling solutions (page 72 – 79)

SPECIAL SOLUTIONS FOR LABS, RESEARCH FACILITIES, SURGERIES AND NURSING HOMES

- Thermoelectric cooling and heat-retaining boxes with factory preset fixed temperature and customer-specific accessories (page 16 – 21)
- Refrigeration and deep-freeze containers as top loaders and front loaders with customer-specific equipment (page 34 – 43)
- Medicine cabinets with silent absorption cooling (DS series) or powerful compressor technology (HC series) (page 48 – 49)
- Built-in stainless steel cabinets with compressor cooling or heating (page 50 – 51)
- Thermoelectric built-in cooler and warmer boxes for laboratory transports (page 52)
- Cooling units and evaporators for converting unused storage space into customised cooling solutions (page 72 – 79)

CUSTOM-DESIGNED COOLING SOLUTIONS

FOR FOOD PROCESSING, HOTELS AND RESTAURANTS

For transporting fresh produce, deep-freeze goods, warm and cold food, the professional cooling range from Dometic offers numerous tried and tested, reliable solutions which provide you with optimal support for adherence to legally required standards such as HACCP and GDP. Benefit from our decades of experience as market leader for mobile refrigeration and our expertise in customising cool boxes and refrigerators. Get inspired from the multitude of possibilities and talk to us if your requirements go beyond of what we have developed in close collaboration with customers, users, experts and vehicle manufacturers. Or use our ColdMachine range of cooling units and evaporators to create your own, customised refrigeration solution.



HIGH-PRECISION COOLING SOLUTIONS FOR FOOD PROCESSING AND INSPECTION

- Thermoelectric cooling and heat-retaining boxes with factory preset fixed temperature and customer-specific accessories (page 16 – 21)
- Compressor refrigeration and deep-freeze coolers with factory preset fixed temperature and customer-specific accessories (page 22 – 31)
- Refrigeration and deep-freeze containers as top loaders and front loaders with customer-specific equipment (page 34 – 43)
- Cooling units and evaporators for converting unused storage space into customised cooling solutions (page 72 – 79)
- Fully-integrated cooling systems for fresh-goods transport (page 60 – 67)

PROFESSIONAL COOLING SOLUTIONS FOR HOTELS, RESTAURANTS AND CATERING

- Refrigeration and deep-freeze containers as top loaders and front loaders with customer-specific equipment (page 34 – 43)
- Milk and beverage coolers for smaller bars and restaurants (page 56 – 57)
- Passive insulation coolers for food transport (page 12 – 15)
- Cooling units and evaporators for converting unused storage space into customised cooling solutions (page 72 – 79)
- Fully-integrated cooling systems for fresh-goods transport (page 60 – 67)



COOL



BOXES

CUSTOMISED COOLING SOLUTIONS
COOL BOXES / COOL-ICE

COOL-ICE PASSIVE COOLERS

DESIGNED FOR THE TOUGHEST CONDITIONS!

Hot outside temperatures, shock and impact during transport, frequent opening and closing, packing and stacking – Dometic Cool-Ice boxes take it all with ease.

For
temperature-
sensitive
produce



**HIGHLY-EFFECTIVE
INSULATION**

EASY TO CLEAN

**NINE SIZES – FROM
13 TO 111 LITRES**

COOLING WITHOUT ELECTRICITY

Dometic Cool-Ice passive coolers, as the name suggests, require no energy supply. This makes them ideal for air freight logistics or other applications where mains or battery power are unavailable. Packed with dry ice or freezer packs, they keep temperature-sensitive goods fresh for several hours. Highly-effective insulation combined with a smart labyrinth seal makes it possible. All Cool-Ice boxes are easy to transport, easy to clean and fitted with handy details for convenient handling.

Highly-effective insulation



ROBUST TETHERING POINTS

Integrated in the handle anchors (WCI 33 or higher).



LABYRINTH SEAL

The labyrinth seal prevents any heat from making its way into the interior.



STABLE HANDLES

Making it easy to transport by one or two people. (WCI 33 or higher)



HEAVY DUTY QUALITY

Fit for the rigors of mobile life – can even be used as a seat or to stand on



FULLY INTEGRATED HINGES

With stainless steel rods for more stability and smooth contours



COOL-ICE CI 85W

with wheels and pull-out handle



COLD-HEAT STORAGE FOR HIGHEST DEMANDS

- Extremely low heat absorption
- Highly effective polyurethane foam insulation, combined with an intelligent labyrinth seal
- High-quality, UV-resistant plastic
- Especially sturdy construction thanks to "seamless" production in rotation procedure
- Integrated hinges with stainless steel rods
- Solid ABS locks with stainless steel attachment bolts
- Integrated polyester feet for improved non-slip stability
- Sturdy, ergonomic handles (from WCI 33 and above)
- High-strength anchor points for securing goods (from WCI 33 and above)
- Comfortable shoulder belt (WCI 13/22/33)
- Practical drain plug for melted ice (from WCI 33 and above)
- Suitable for food and easy to clean
- Optimised volume/weight ratio
- Available in nine sizes: 13, 22, 33, 43, 56, 71, 86, 87 and 111 litres

Product	Ref. No.	Capacity (litres)	Weight (kg)
Dometic Cool-Ice WCI 13	9600000500	13	2.8
Dometic Cool-Ice WCI 22	9600000501	22	4.2
Dometic Cool-Ice WCI 33	9600000502	33	5.7
Dometic Cool-Ice CI 42	9600000541	43	8.7
Dometic Cool-Ice CI 55	9600000542	56	10.6
Dometic Cool-Ice CI 70	9600000543	71	11.8
Dometic Cool-Ice CI 85	9600000544	87	14
Dometic Cool-Ice CI 85W with wheels	9600000545	86	14.6
Dometic Cool-Ice CI 110	9600000546	111	18.1



MEASUREMENTS DOMETIC COOL-ICE

DOMETIC COOL-ICE WCI 13

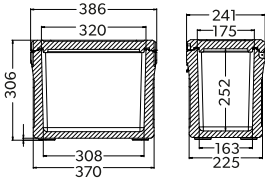

DOMETIC COOL-ICE WCI 22

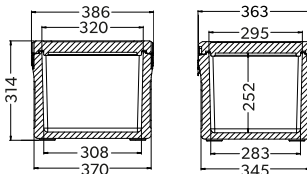

DOMETIC COOL-ICE WCI 33

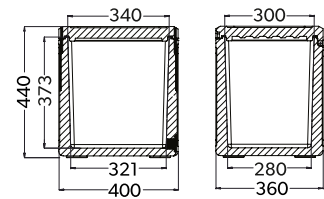

DOMETIC COOL-ICE CI 42

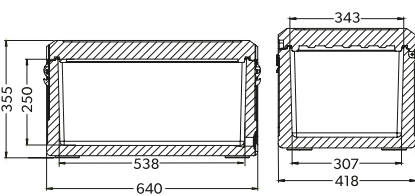

DOMETIC COOL-ICE CI 55

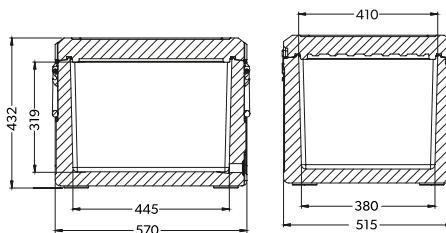

DOMETIC COOL-ICE CI 70

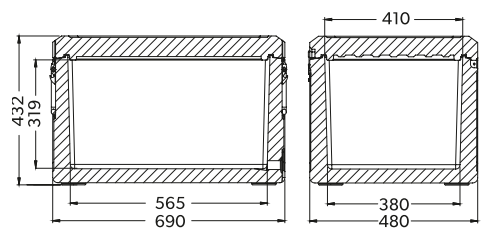

DOMETIC COOL-ICE CI 85 AND CI 85W

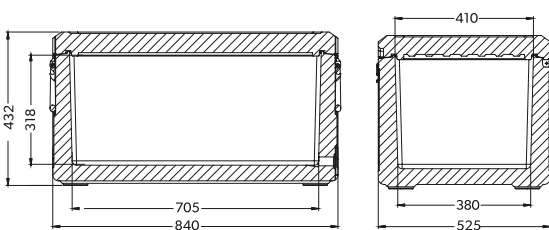

DOMETIC COOL-ICE CI 110

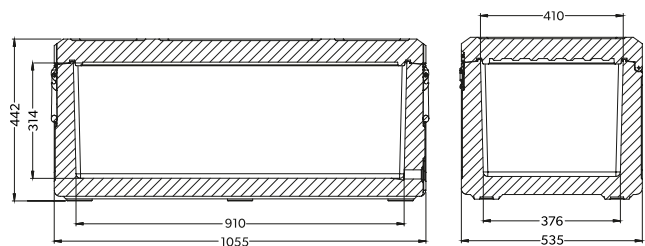

TROPICOOOL THERMOELECTRIC COOLERS

12 VOLTS DC OR 230 VOLTS AC AS STANDARD!

Lightweight, low-priced, versatile – these are the hallmarks of thermoelectric refrigeration. The maintenance free cooling technology is great for low-capacity heating or cooling of small to medium-sized spaces. It is based on the thermoelectric principle – which states that heat or cold is generated when the connection between different metals is linked to a direct current power source

(Peltier effect). The Dometic TropiCool range (p. 18/19) offers you three different sizes – from the compact 14-litre box to the large 33-litre volume model. All models come with special TC electronics as standard plus a digital display and come pre-wired for 12 V DC and 230 V AC.



12 V



230 V



COOLING AND
HEATING
MODE



ACTIVE
BATTERY
PROTECTION



ENERGY CLASS A++

**UP TO 27 °C BELOW
AMBIENT TEMPERATURE**

**UP TO +65 °C
IN HEATING MODE**

TEMPERATURE REGULATION DOWN TO THE DEGREE

For temperature controlled transports, all the TropiCool boxes can be equipped with highly sophisticated special electronics (see page 20/21) for setting the exact temperature. The soft-touch control panel can be replaced by a digital display.



Thermoelectrics
+ specialised
modules
= Tailor made
temperature

Aerospace technology for cooling and heating: the thermoelectric Peltier element works accurately, maintenance free and without any refrigerant.

SOPHISTICATED TECHNOLOGY FOR EXCELLENT USER CONVENIENCE

Dometic TropiCool coolers provide cooling up to 27 °C below ambient temperature and heating up to +65 °C. Using the soft-touch operating panel, you can set the desired temperature in seven stages each: from +1 °C to +15 °C in the cooling mode, or from +50 °C to +65 °C in the heating mode. The memory function saves the last set parameters.

PRODUCT BENEFITS

- Cooling up to 27 °C below ambient temperature
- Heating up to +65 °C
- 7-stage temperature control in cooling and heating mode
- LED temperature readout
- Memory function saves last setting
- Membrane keypad protects the electronics from dust and moisture
- Active battery protection prevents deep discharge of the vehicle battery
- Reverse polarity protection

- 1 TC SPECIAL ELECTRONICS**
With soft-touch control panel and active battery protection
- 2 HIGHLY EFFECTIVE INSULATION**
High level of efficiency
- 3 DYNAMIC INTERIOR VENTILATION**
Significantly improved cooling capacity
- 4 MAINTENANCE FREE FAN**
Long service life
- 5 INTELLIGENT ENERGY-SAVING CIRCUIT**
Electronics switch automatically to power-save mode once the desired interior temperature has been reached.
- 6 12/230 V CONNECTION AS STANDARD**
With priority circuit for 230 V
- 7 HEAT EXCHANGER AND HIGH-PERFORMANCE PELTIER ELEMENT**
Cooler output up to 27 °C less than ambient temperature!
- 8 MAGNETIC SWITCH**
Switches the interior fan off automatically when you open the box
- 9 UNIVERSAL FIXING KIT AS ACCESSORY**





DOMETIC TROPICOOOL TCX 14

THERMOELECTRIC COOLER WITH TC SPECIAL ELECTRONICS

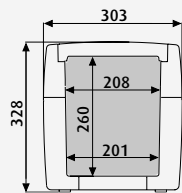
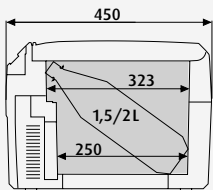

Storage volume	approx. 14 litres
Connection voltage	12 volts DC and 230 volts AC
Power consumption	approx. 46 watts at 12 volts DC approx. 64 watts at 230 volts
Temperature range	Cooling: +1 °C to +15 °C (up to 27 °C below the ambient temperature); heating: +50 °C to +65 °C
Insulation	PU full foam insulation
System	Wear-free thermoelectrics (Peltier system), cold transmission to the interior by dynamically ventilated aluminium heat exchanger, heat dissipation to the outside by high-performance heat exchanger and brushless, no wear and tear on the fan
Material	Sturdy, injection moulded parts
Colour	Dark grey/pale grey
Weight	approx. 5.0 kg
Quality features	TC special electronics: 7-stage electronic thermostat with LED indicators, memory function, ON/OFF and cold/warm option activated with soft-touch operating panel, intelligent powersave circuit. Integrated mains supply unit with priority circuit, outstanding cooling performance, with active battery protection, reverse polarity protection, magnetic switch to deactivate the interior fan when the box is opened, detachable lid with magnetic closure, sturdy, fold-away handle
Test marks	TÜV/GS, e-approved (Automotive EMC Directive)
Ref. No.	9103540486 / UK 9600010637



COOLING AND HEATING MODE



ACTIVE BATTERY PROTECTION



12 V



230 V



ENERGY CLASS

/ Optional extras

Universal fixing kit	9105303709
----------------------	------------

UNIVERSAL FIXING KIT

FOR TROPICOOOL TCX 14, TCX 21, TCX 35: FOR FASTENING OF TROPICOOOL COOLERS IN VEHICLES.



Material	Powder-coated metal
Colour	Black
Scope of delivery	Two base plates, two adjustable straps, set of screws
Ref. No.	9105303709

DOMETIC TROPICOOOL TCX 21

THERMOELECTRIC COOLER WITH TC SPECIAL ELECTRONICS

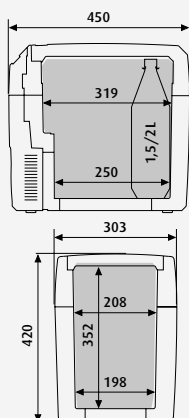

Storage volume	approx. 20 litres
Connection voltage	12 volts DC and 230 volts AC
Power consumption	approx. 46 watts at 12 volts DC approx. 64 watts at 230 volts
Temperature range	Cooling: +1 °C to +15 °C (up to 27 °C below the ambient temperature); heating: +50 °C to +65 °C
Insulation	PU full foam insulation
System	See TCX 14
Material	Sturdy, injection moulded parts
Colour	Dark grey/pale grey
Weight	approx. 6.0 kg
Quality features	TC special electronics: 7-stage electronic thermostat with LED indicators, memory function, ON/OFF and cold/warm option activated with soft-touch operating panel, intelligent powersave circuit. Integrated mains supply unit with priority circuit, outstanding cooling performance, with active battery protection, reverse polarity protection, magnetic switch to deactivate the interior fan when the box is opened, detachable lid with magnetic closure, sturdy, fold-away handle, vertical space for 2 litre bottles, adjustable grid divider
Test marks	TÜV/GS, e-approved (Automotive EMC Directive)
Ref. No.	9103540487 / UK 9600010638
/ Optional extras	
Universal fixing kit	9105303709



DOMETIC TROPICOOOL TCX 35

THERMOELECTRIC COOLER WITH TC SPECIAL ELECTRONICS

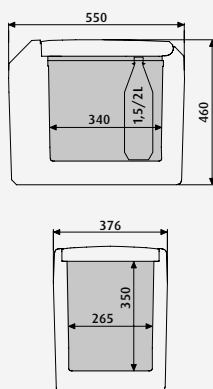

Storage volume	approx. 33 litres
Connection voltage	12 volts DC and 230 volts AC
Power consumption	approx. 46 watts at 12 volts DC approx. 64 watts at 230 volts
Temperature range	Cooling: +1 °C to +15 °C (up to 27 °C below the ambient temperature); heating: +50 °C to +65 °C
Insulation	PU full foam insulation
System	See TCX 14
Material	Sturdy, injection moulded parts
Colour	Dark grey/pale grey
Weight	approx. 10.0 kg
Quality features	TC special electronics: 7-stage electronic thermostat with LED indicators, memory function, ON/OFF and cold/warm option activated with soft-touch operating panel, intelligent powersave circuit. Integrated mains supply unit with priority circuit, outstanding cooling performance, with active battery protection, reverse polarity protection, magnetic switch to deactivate the interior fan when the box is opened, detachable lid with snap lock closure, handy carrying grips, vertical space for 2-litre bottles, adjustable grid divider
Test marks	TÜV/GS, e-approved (Automotive EMC Directive)
Ref. No.	9103540488 / UK 9600010639
/ Optional extras	
Universal fixing kit	9105303709



CUSTOMISING WITH EXTRA MODULES

DATA LOGGER FOR EASY DOCUMENTATION

For the sake of continuous, tamper-proof temperature recording, the DT-07N data logger is firmly integrated in the cooler. The data is imported into the laptop via a data transfer cable with USB – or printed out directly using the clip-on printer. Alternatively, we offer a disposable data logger for documenting the temperature progression (DT-21).



EXTRA MODULES FOR THERMOELECTRIC COOLERS

THERMOELECTRIC COOLERS	DTTC-02 ONE FACTORY PRESET FIXED TEMPERATURE	DT-07N DATA LOGGER	DT-08N THERMAL PRINTER INCL. DATA LOGGER WITH SOFTWARE	DTTC-09 TWO FACTORY PRESET FIXED TEMPERATURES	DT-13 3-PIN PLUG-IN SYSTEM	DTTC-17 ALARM FUNCTION	DT-21 DISPOSABLE DATA LOGGER
TCX 14	•	•	•	•	•	•	•
TCX 21	•	•	•	•	•	•	•
TCX 35	•	•	•	•	•	•	•



EXTRA MODULES FOR THERMOELECTRIC COOLERS



DTTC-02

Setting a fixed temperature in the range from +10 °C to +40 °C (automatic heating or cooling). Max. 27 °C below or 30 °C above ambient temperature. With digital temperature display. Tolerance: ± 2 °C. Test report included in the scope of delivery.

Ref. No. 9600024729

(* Image similar)



DTTC-09

Two fixed temperatures in a range from +10 °C to +40 °C (automatic heating or cooling). Max. 27 °C below or 40 °C above ambient temperature. With digital temperature display. Easy change from one value to another with rocker switch. Tolerance: ± 2 °C. Test report included in the scope of delivery.

Ref. No. 9600024730

(* Image similar)



DTTC-17

Alarm will be triggered by a deviation from the target temperature ± 4.0 °C lasting more than 5 min. The alarm function is activated 20 min after the cooler starts operating. In combination with DTTC-02 and DTTC-09 only!

Ref. No. 9103540026



DT-07N

Temperature data logger as a single unit, without software. Software download from www.testo.com

Ref. No. 9103540007



DT-21

Disposable data logger for recording temperature in the cooler. Up to 90 days recording time following activation (USB interface)

Ref. No. 9103540134



DT-08N

Thermal printer for displaying the temperature variation graphically (to be used in combination with DT-07N).

Ref. No. 9103540008



DT-13

3-pin plug-in system for built-in power supply. Max. power consumption: 25 A at 12 volts. Flat terminals (4 x 6.3 mm or 1 x 4.8 mm).

Ref. No. 2225400001



12/24 V



100 - 240 V



SOLAR
OPERATION

COOLFREEZE COMPRESSOR COOLERS

PERFECT FOR DEMANDING LOGISTICAL CHALLENGES



Excellent cooling and freezing performance, low energy consumption – features you can depend on with each compressor appliance from Dometic. The CoolFreeze range offers a matching appliance for every demand – from a compact 10.5-litre box right through to a roomy 85-litre cool box.

All CDF and CFX boxes are pre-wired for 12/24 V DC and 100 – 240 V AC.

PICK WHAT YOU NEED – WE DO THE FITTING

For complex logistical applications in laboratory systems, human and veterinary medicine, we fit our tried and trusted compressor coolers with customer-specific extra modules (see page 30/31). One or two factory-preset fixed temperature(s), an additional heater for safe operation at low temperatures, a data logger for easy documentation ... there are number of ways of preparing Dometic CoolFreeze compressor coolers for special requirements.

As an additional safety feature the coolers come equipped with a smartphone app, which you can use to access the current temperature in the cooler at any time from your phone. In parallel to this, data is stored on an external server. This can be accessed with a personal PIN for the documentation.



- 1 SOFT-TOUCH OPERATOR PANEL**
Dust and water-proof; digital temperature display
- 2 HIGH-QUALITY MATERIALS**
Housing made of injection moulded components
- 3 PERFECT PROCESSING**
Optimal function, long life
- 4 POWERFUL COMPRESSOR TECHNOLOGY**
Excellent cooler performance even under extreme exterior temperatures; precise temperature control $\pm 1^\circ\text{C}$
- 5 FLEXIBLE ENERGY SUPPLY**
12/24 V or 12/24 V and 100 – 240 V
- CONFIGURED FOR THE CUSTOMER**
with accessories (p. 30/31)

DOMETIC COOLFREEZE CDF

LIGHTWEIGHT COMPRESSOR TECHNOLOGY

Light, compact compressor coolers – easy to handle and accommodate onboard. Refrigeration and deep-freezing down to $-18\text{ }^{\circ}\text{C}$ with minimal power consumption, regardless of the outside temperature.

- 12/24 V DC
- 2 sizes: approx. 10,5 and 18 litres

Please note: Freezing function at ambient temperature max $+32\text{ }^{\circ}\text{C}$. Standard cooling function at ambient temperature max. $43\text{ }^{\circ}\text{C}$



DOMETIC COOLFREEZE CFX

COMPRESSOR COOLING WITHOUT COMPROMISE

Energy class A++ and deep-freeze temperatures down to $-22\text{ }^{\circ}\text{C}$. Up to 35 % lower energy use thanks to a specially-developed high-performance compressor and extra-strong insulation. Heavy-duty design.

- 12/24 V DC and 100 – 240 V AC
- CFX special electronics with soft-start and turbo cooler function
- 5 versions of approx 32 – 85 litres

Please note: Freezing function at ambient temperature max $+32\text{ }^{\circ}\text{C}$. Standard cooling function at ambient temperature max. $43\text{ }^{\circ}\text{C}$



DOMETIC COOLFREEZE CDF 11

PORTABLE COMPRESSOR COOLER FOR REFRIGERATION AND DEEP-FREEZING

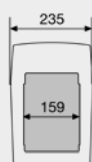
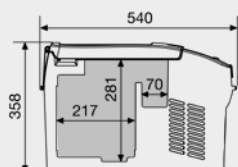

Storage volume	approx. 10.5 litres
Connection voltage	12/24 volts DC
Power consumption	approx. 35 watts
Current consumption at +5 °C interior temperature	0.29 Ah/h (at +20 °C ambient temperature) 0.61 Ah/h (at +32 °C ambient temperature)
Temperature range	+10 °C to -18 °C, adjustable using electronic thermostat
Refrigerant	The cooling circuit contains the fluorinated greenhouse gas R 134a (28 g), CO ₂ equivalent: 0.042 t, GWP: 1430
Insulation	PU full foam insulation
System	Compressor with integrated control electronics, low voltage protection (can be disabled), electronic fuse/automatic reverse pole protection
Material	Housing: PP; lid: PE
Colour	Dark grey/pale grey
Weight	approx. 8.5 kg
Quality features	Electronic thermostat with digital temperature display, 3-stage battery monitor, LED interior light, adjustable shoulder strap, two drink holders, easy and secure fastening with the vehicle safety belt
Scope of delivery	DC connection cable
Test marks	e-approved (Automotive EMC Directive)
Ref. No.	9103540285
/ Optional extras	
Trolley	see page 31



TEMPERATURE RANGE
+10 °C TO -18 °C



SUITABLE FOR SOLAR OPERATION



12/24 V

DOMETIC COOLFREEZE CDF 18

PORTABLE COMPRESSOR COOLER FOR REFRIGERATION AND DEEP-FREEZING

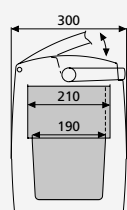
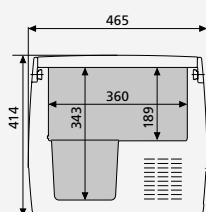

Storage volume	approx. 18 litres
Connection voltage	12/24 volts DC
Power consumption	approx. 35 watts
Current consumption at +5 °C interior temperature	0.38 Ah/h (at +20 °C ambient temperature) 0.61 Ah/h (at +32 °C ambient temperature)
Temperature range	+10 °C to -18 °C, adjustable using electronic thermostat
Refrigerant	The cooling circuit contains the fluorinated greenhouse gas R 134a (32 g), CO ₂ equivalent: 0.046 t, GWP: 1430
Insulation	PU full foam insulation
System	Compressor with integrated control electronics, low voltage protection adjustable for leisure and starter battery via slide switch, electronic fuse / automatic reverse pole protection, dynamically ventilated wire tube condenser, aluminium rollbond evaporator
Material	Housing: PP; lid: PE
Colour	Dark grey/pale grey
Weight	approx. 9.5 kg
Quality features	Detachable fold-up lid, sturdy carrying handle, vertical space for standing 2-litre bottles
Scope of delivery	DC connection cable
Test marks	TÜV/GS, e-approved (Automotive EMC Directive)
Ref. No.	9103540485
/ Optional extras	
Mains adapter 230 V ~ 24 V	EPS 100, 9600000440
Trolley	see page 31



TEMPERATURE RANGE
+10 °C TO -18 °C



SUITABLE FOR SOLAR OPERATION



12/24 V

CUSTOMISED COOLING SOLUTIONS
COOL BOXES / COOLFREEZE CFX

COOLFREEZE CFX COMPRESSOR COOLERS

OUR MOST POWERFUL COMPRESSOR COOLERS EVER!

Energy class A++, freezing down to $-22\text{ }^{\circ}\text{C}$, 35 % lower energy consumption versus comparable models:
With its CFX series compressor coolers, once again Dometic shows how to set benchmarks.
These high-tech devices show their worth in use with compact equipment details:
Corner reinforcements, stainless steel hinges and lid coating withstand the toughest of stresses.



12/24 V



100 – 240 V



SOLAR
OPERATION



**DEEP FREEZING
DOWN TO $-22\text{ }^{\circ}\text{C}$**

**UP TO 35 % LESS POWER
CONSUMPTION!**

HEAVY-DUTY VERSION

STAY COOL!

Fitted with heavy-duty details like reinforced corners, stainless-steel hinges and a robust lid lining, the hi-tech coolers in the CFX series can withstand the most demanding of loads. Even so, they are remarkably lightweight and easy to transport.

- Suitable for deep freezing down to $-22\text{ }^{\circ}\text{C}$
- Excellent cooling performance even at extremely high outside temperatures
- 12/24 volts DC and 100 – 240 volts AC
- CFX special electronics with digital temperature display
- Extremely efficient and superbly quiet operation
- USB port
- Drain plugs make cleaning simple
- Suitable for solar operation
- Heavy-duty version



POWER

12/24 volts DC and 100 – 240 volts AC



DETACHABLE LID

Heavy-duty version with reinforced corners, robust closing mechanism







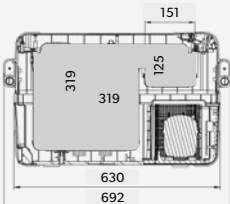
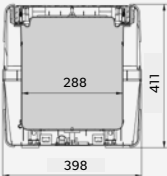

CONNECTIVITY

USB port for charging small electronic devices

DOMETIC COOLFREEZE CFX 35W

ENERGY-SAVING COMPRESSOR COOLER FOR REFRIGERATION AND DEEP-FREEZING

  	Storage volume	32 litres (incl. 4.5 litres for fresh food)	 TEMPERATURE RANGE $+10\text{ }^{\circ}\text{C}$ TO $-22\text{ }^{\circ}\text{C}$  SUITABLE FOR SOLAR OPERATION  12/24 V  100 – 240  ENERGY CLASS
	Connection voltage	12/24 volts DC and 100 – 240 volts AC	
	Power consumption	approx. 43 watts	
	Current consumption	0.32 Ah/h (at $+20\text{ }^{\circ}\text{C}$ ambient temperature), 0.60 Ah/h (at $+32\text{ }^{\circ}\text{C}$ ambient temperature), both at $+5\text{ }^{\circ}\text{C}$ interior temperature	
	Temperature range	$+10\text{ }^{\circ}\text{C}$ to $-22\text{ }^{\circ}\text{C}$, freely adjustable using electronic thermostat with digital temperature display	
	Refrigerant	The cooling circuit contains the fluorinated greenhouse gas R 134a (38 g), CO_2 equivalent: 0.047 t, GWP: 1430	
	Insulation	PU full foam insulation	
	System	Fully hermetic compressor with integrated control electronics, low voltage protection adjustable for leisure and starter battery via electronic system, electronic fuse / automatic reverse pole protection, dynamically ventilated wire tube condenser, aluminium rollbond evaporator	
	Material	Cabinet: PP + ABS, lid: PE	
	Colour	Dark grey/pale grey	
Weight	approx. 17.5 kg		
Quality features	Detachable lid (lid mount, at the front), interior light, CFX special electronics with soft start and turbo cooler, removable wire basket, 3-stage battery protection		
Scope of delivery	DC- and AC connection cable		
Test marks	TÜV/GS, e-approved (Automotive EMC Directive)		
Ref. No.	9103540290 / UK 9600010568		
/ Optional extras	see page 31		
Trolley			

DOMETIC COOLFREEZE CFX 40W

COMPRESSOR COOLER FOR REFRIGERATION AND DEEP-FREEZING WITH CFX SPECIAL ELECTRONICS

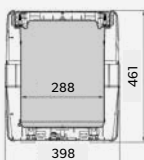
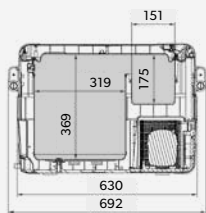

Storage volume	38 litres (incl. 7 litres for fresh food)
Connection voltage	12/24 volts DC and 100 – 240 volts AC
Power consumption	approx. 48 watts
Current consumption at +5 °C interior temperature	0.36 Ah/h (at +20 °C ambient temperature) 0.64 Ah/h (at +32 °C ambient temperature)
Temperature range	+10 °C to –22 °C, freely adjustable using electronic thermostat with digital temperature display
Refrigerant	The cooling circuit contains the fluorinated greenhouse gas R 134a (38 g), CO ₂ equivalent: 0.054 t, GWP: 1430
Insulation	PU full foam insulation
System	see CFX 100W
Material	Cabinet: PP + ABS, lid: PE
Colour	Dark grey/pale grey
Weight	approx. 18.5 kg
Quality features	Deep freezing down to –22 °C, excellent cooling performance even at extremely high outside temperatures, special CFX electronics with digital temperature display, extremely efficient and superbly quiet operation, USB connection, drain plugs make cleaning simple
Scope of delivery	DC and AC connection cable, detachable wire basket, detachable carrying handles
Test marks	TÜV/GS, e-approved (Automotive EMC Directive)
Ref. No.	9103540291 / UK 9600010569
/ Optional extras	
Trolley	see page 31



TEMPERATURE RANGE
+10 °C TO –22 °C



SUITABLE FOR SOLAR OPERATION



12/24 V



100 – 240 V



ENERGY CLASS

DOMETIC COOLFREEZE CFX 50W

COMPRESSOR COOLER FOR REFRIGERATION AND DEEP-FREEZING WITH CFX SPECIAL ELECTRONICS

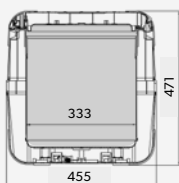
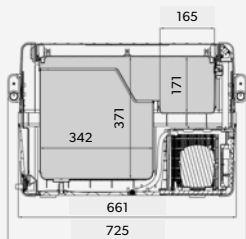

Storage volume	approx 46 litres (incl. 8.5 litres for fresh food)
Connection voltage	12/24 volts DC and 100 – 240 volts AC
Power consumption	approx. 52 watts
Current consumption at +5 °C interior temperature	0.38 Ah/h (at +20 °C ambient temperature) 0.68 Ah/h (at +32 °C ambient temperature)
Temperature range	+10 °C to –22 °C, freely adjustable using electronic thermostat with digital temperature display
Refrigerant	The cooling circuit contains the fluorinated greenhouse gas R 134a (43 g), CO ₂ equivalent: 0.062 t, GWP: 1430
Insulation	PU full foam insulation
System	see CFX 100W
Material	Housing: PP + ABS, lid: PE
Colour	Dark grey/pale grey
Weight	approx. 20.4 kg
Quality features	Deep freezing down to –22 °C, excellent cooling performance even at extremely high outside temperatures, special CFX electronics with digital temperature display, extremely efficient and superbly quiet operation, USB connection, drain plugs make cleaning simple
Scope of delivery	DC and AC connection cable, detachable wire basket, detachable carrying handles
Test marks	TÜV/GS, e-approved (Automotive EMC Directive)
Ref. No.	9103540292 / UK 9600010602
/ Optional extras	
Trolley	see page 31



TEMPERATURE RANGE
+10 °C TO –22 °C



SUITABLE FOR SOLAR OPERATION



12/24 V









100 – 240 V

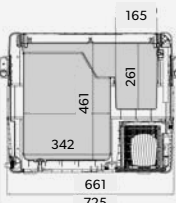





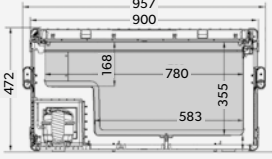
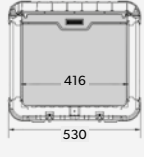

ENERGY CLASS

DOMETIC COOLFREEZE CFX 65W

COMPRESSOR COOLER FOR REFRIGERATION AND DEEP-FREEZING WITH CFX SPECIAL ELECTRONICS			
  	Storage volume	approx. 60 litres (incl. 13 litres for fresh food)	 TEMPERATURE RANGE +10 °C TO -22 °C  SUITABLE FOR SOLAR OPERATION  12/24 V  100 – 240 V  ENERGY CLASS
	Connection voltage	12/24 volts DC and 100 – 240 volts AC	
	Power consumption	approx. 58 watts	
	Current consumption at +5 °C interior temperature	0.42 Ah/h (at +20 °C ambient temperature) 0.76 Ah/h (at +32 °C ambient temperature)	
	Temperature range	+10 °C to -22 °C, freely adjustable using electronic thermostat with digital temperature display	
	Refrigerant	The cooling circuit contains the fluorinated greenhouse gas R 134a (57 g), CO ₂ equivalent: 0.082 t, GWP: 1430	
	Insulation	PU full foam insulation	
	System	see CFX 100W	
	Material	Housing: PP + ABS, lid: PE	
	Colour	Dark grey/pale grey	
	Weight	approx. 22.3 kg	
	Quality features	see CFX 50W	
	Scope of delivery	DC and AC connection cable, detachable wire basket, detachable carrying handles	
	Test marks	TÜV/GS, e-certified (Automotive EMC Directive)	
Ref. No.	9103540293 / UK 9600010603		
/ Optional extras			
Trolley	see page 31		

DOMETIC COOLFREEZE CFX 100W*

COMPRESSOR COOLER FOR REFRIGERATION AND DEEP-FREEZING WITH CFX SPECIAL ELECTRONICS			
  	Storage volume	approx. 88 litres	 TEMPERATURE RANGE +10 °C TO -22 °C  SUITABLE FOR SOLAR OPERATION  12/24 V  100 – 240 V  ENERGY CLASS
	Connection voltage	12/24 volts DC and 100 – 240 volts AC	
	Power consumption	approx. 65 watts	
	Current consumption at +5 °C interior temperature	0.75 Ah/h (at +20 °C ambient temperature) 1.25 Ah/h (at +32 °C ambient temperature)	
	Refrigerant	The cooling circuit contains the fluorinated greenhouse gas R 134a (64 g), CO ₂ equivalent: 0.092 t, GWP: 1430	
	Temperature range	+10 °C to -22 °C, freely adjustable using electronic thermostat with digital temperature display	
	Insulation	PU full foam insulation	
	System	Fully hermetic compressor with integrated control electronics, low voltage protection adjustable for leisure and starter battery via electronic system, electronic fuse / automatic reverse pole protection, dynamically ventilated wire tube condenser, aluminium rollbond evaporator	
	Material	Housing: PP + ABS, lid: PE	
	Colour	Dark grey/pale grey	
	Weight	approx. 32 kg	
	Quality features	see CFX 50W	
	Scope of delivery	DC and AC connection cable, detachable wire basket, detachable carrying handles	
	Test marks	TÜV/GS, e-certified (Automotive EMC Directive)	
Ref. No.	9600002992* / UK 9600010636		
/ Optional extras			
Trolley	see page 31		

EXTRA MODULES FOR COMPRESSOR COOLERS

	DT-02 ONE FACTORY PRESET FIXED TEMPERATURE	DT-09 TWO FACTORY PRESET FIXED TEMPERATURES	DT-04 INTERIOR FAN	DT-05* HEATER WITH THREE-POINT CONTROL	DT-17 ALARM FUNCTION	DT-07N DATA LOGGER	DT-08N THERMAL PRINTER	DT-21 DISPOSABLE DATA LOGGER	DT-29 BATTERY PACK	DT-13 3-PIN PLUG-IN SYSTEM	DT-15 TROLLEY
CDF 11	•	•	•		•	•	•	•	•	•	•
CDF 18	•	•	•	•	•	•	•	•	•	•	•
CFX 35W	•	•	•	•	•	•	•	•	•	•	•
CFX 40W	•	•	•	•	•	•	•	•	•	•	•
CFX 50W	•	•	•	•	•	•	•	•	•	•	•
CFX 65W	•	•	•	•	•	•	•	•	•	•	•
CFX 100W	•	•	•	•	•	•	•	•	•	•	•

* Operation with 12 or 24 volts only. Operation with 230 volts not possible. Except CFX 100W.



DT-02

One fixed temperature (cooling only) with digital temperature display in a range from -18 °C (CDF)/ -22 °C (CFX) to +10 °C. Tolerance: ± 2 °C. Test report included in the scope of delivery. If the set temperature is above the expected lowest ambient temperature, the DT 05 heater is required.

Ref. No. 9600024731

(* Image similar)



DT-09

Two fixed temperatures (cooling only) with digital temperature display in a range from -18 °C (CDF)/ -22 °C (CFX) to +10 °C. Easy change from one value to another with rocker switch. Tolerance: ± 2 °C. Test report included in the scope of delivery. If the set temperature is above the expected lowest ambient temperature, the DT 05 heater is required.

Ref. No. 9600024732

(* Image similar)



DT-04

High-performance fan for fast cooling or heating and uniform air circulation inside the box (recommended for CFX series). Storage capacity will be reduced by approx. 100 x 100 x 30 mm WxHxD.

Ref. No. 9103540004

Attention: Only useful in conjunction with DT-02 / DT-09.

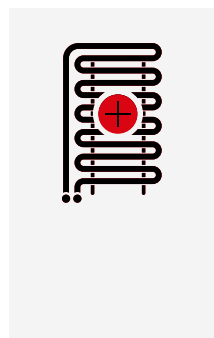

DT-05

Heater for safer operation at low outside temperatures (if set temperature is above the ambient temperature). Includes DT 04 fan. Operation with 12 or 24 volts only. Operation with 230 volts not possible. Except CFX 100W.

Ref. No. 9103540005



DT-17

Alarm will be triggered by a deviation from the target temperature ± 4.0 °C lasting more than 5 min. The alarm function is activated 20 min after the cooler starts operating. In combination with DT-04 and DT-02 or DT-09 only!

Ref. No. 9103540015



DT-07N

Temperature data logger as a single unit, without software. Software download from www.testo.com

Ref. No. 9103540007



DT-08N

Thermal printer for displaying the temperature variation graphically (to be used in combination with DT-07N).

Ref. No. 9103540008



DT-21

Disposable data logger for recording temperature in the cooler. Up to 90 days recording time following activation (USB interface)

Ref. No. 9103540134



DT-29

Battery pack for the power supply of 24-volt compressor coolers
Energy = 240 Wh

Ref. No. 9103540044



DT-13

3-pin plug-in system for built-in power supply.
Max. power consumption: 25 A at 12 volts. Flat terminals (4 x 6.3 mm or 1 x 4.8 mm).

Ref. No. 2225400001



DT-15

Folding trolley with elastic strap and large, easy-running wheels. Only available when purchasing a cooler!

490 x 1130 x 410 mm (W x H x D)

Ref. No. 9103540013



PORTABLE LITHIUM BATTERY

SUPERIOR PERFORMANCE – RELIABLE POWER SUPPLY

The Dometic PLB40 Ah Lithium Iron Phosphate battery delivers high levels of mobile power – up to 40 hours of Dometic CFX 40W cooling on a single charge. Designed for powering powered coolers and other 12 V appliances while being off-grid. Thanks to its lightweight and compact design you can enjoy true independence and travel off-grid for longer.

Ref. No. 9600012878



reddot design award
winner 2019

For more information see dometic.com





COO CONTA



LING INERS

REFRIGERATION AND DEEP-FREEZE CONTAINERS FROM DOMETIC

AS A TOP LOADER OR FRONT LOADER

Ice cream vans, on-line produce delivery, fresh goods from wholesalers – these cooler containers from Dometic offer safe, tailor-made, cooling solutions. Available as a front loader or top loader, each in three sizes (209 / 435 / 590 litres). Easy-to-operate slide doors, pallet feet and transport rollers (accessories) ensure comfortable handling. The optional battery set (page 43) can retain the set temperature for up to 8 hours without an external power supply.



12 V



230 V



FIXED
TEMPERATURE
CAN BE SWITCHED



Pallet feet
come as
standard!**

ILLUSTRATION
SHOWS
ACCESSORIES

TOP LOADER (+4 °C / -18 °C FIXED TEMPERATURE*)

- Two factory-set fixed temperatures: +4 °C / -18 °C*
- Toploading, minimum refrigeration losses
- Heavy-duty design – sturdy with long life expectancy
- Pallet feet for secure loading and unloading with fork-lifts
- Attachments to tie the box safely down in the vehicle
- Customer-specific accessories (e.g. battery set, transport rollers, data logger, page 43)



Independent energy supply: The optional battery set ensures a constant cooling temperature for up to 8 hours (at an external temperature of 32 °C), without an external power supply.

PERFECTLY EQUIPPED FOR YOUR LOGISTICS

CONTROL DOWN TO THE EXACT TEMPERATURE – WITH MANY PRACTICAL EXTRAS



PRODUCE DELIVERY SERVICE

More and more customers are having food, vegetables, dairy products and frozen goods delivered directly to their door. With the new refrigeration and deep-freeze boxes from Dometic, transport firms assure the cooling chain remains complete from supermarket or warehouse to the consumer as a legal requirement.



DELIVERY LOGISTICS FOR BARS AND RESTAURANTS

Customised Cooling Solutions chain management in bars and restaurants begins with the purchase of produce at the wholesaler. The required refrigeration temperature must be met at all times. Loading and unloading is much more convenient with Dometic cooling containers.

FRONT LOADER (+4 °C FIXED TEMPERATURE*)

- A factory-set fixed temperature: +4 °C*
- Frontloading, top can be used for storage
- Heavy-duty design – rugged, long-life
- Pallet feet for safe loading and unloading with fork-lifts
- Attachments to tie the box safely down in the vehicle
- Customer-specific accessories (e.g. battery set, transport rollers, data logger, page 43)



HEAVY-DUTY EQUIPMENT:

with locking and easy-to-operate slider doors



TEMPERATURE SWITCH KEY

Simple, safe configuration of fixed temperature in toploaders



ATTACHMENT POINTS

For safe fixing or tying down of the refrigeration containers in the vehicle



FLEXIBLE POWER SUPPLY

230 V AC, 12 V DC, in part also with 24 V DC, independent operation possible with battery set

*At an external temperature of +38 °C
** With FO1000, FO650 and FO850

DOMETIC TL200

HEAVY-DUTY REFRIGERATION AND DEEP-FREEZE CONTAINER WITH TWO FACTORY PRESET FIXED TEMPERATURES (CAN BE SWITCHED)

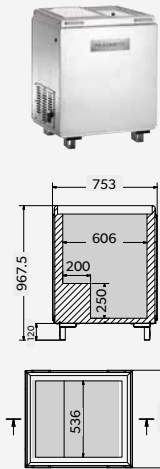

Capacity (l)	Storage volume: 188
Voltage	12 volts DC and 230 volts AC (24 volts DC on request)
Power consumption	300 watts
Temperature range	Fixed temperature +4 °C / -18 °C (at an ambient temperature of max. +38 °C)
Refrigerant	The cooling circuit contains the fluorinated greenhouse gas R 404a (150 g), CO ₂ equivalent: 0,588 t, GWP: 3922
Insulation	Polyurethane
System	DC: Compressor, AC: with built-in power supply
Material	Sheet steel housing
Dimensions (W x H x D)	753 x 967,5 x 685 mm
Weight	110 kg
Quality features	Heavy-duty design, two fixed temperatures: +4 °C / -18 °C*, pallet feet for safe loading and unloading with fork-lifts; attachment points for safe storage on-board; transport rollers as accessories
Ref. No.	9103540405



PRESET FIXED TEMPERATURE CAN BE SWITCHED BETWEEN +4 °C / -18 °C (AT AN AMBIENT TEMPERATURE OF MAX. +38 °C)



12 V



230 V

/ Optional extras see page 43

DOMETIC TL300

HEAVY-DUTY REFRIGERATION AND DEEP-FREEZE CONTAINER WITH TWO FACTORY PRESET FIXED TEMPERATURES (CAN BE SWITCHED)

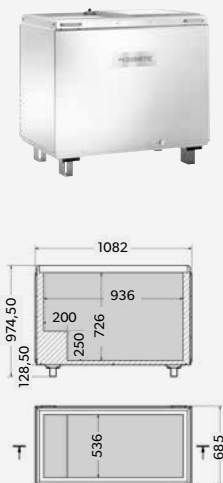

Capacity (l)	Storage volume: 304
Voltage	12 volts DC and 230 volts AC (24 volts DC on request)
Power consumption	300 watts
Temperature range	Fixed temperature +4 °C / -18 °C (at an ambient temperature of max. +38 °C)
Refrigerant	The cooling circuit contains the fluorinated greenhouse gas R 404a (160 g), CO ₂ equivalent: 0,628 t, GWP: 3922
Insulation	Polyurethane
System	DC: Compressor, AC: with built-in power supply
Material	Sheet steel housing
Dimensions (W x H x D)	1082 x 974,5 x 685 mm
Weight	150 kg
Quality features	Heavy-duty design, two fixed temperatures: +4 °C / -18 °C*, pallet feet for safe loading and unloading with fork-lifts; attachment points for safe storage on-board; transport rollers as accessories, green status-LED
Ref. No.	9600022114



PRESET FIXED TEMPERATURE CAN BE SWITCHED BETWEEN +4 °C / -18 °C (AT AN AMBIENT TEMPERATURE OF MAX. +38 °C)



12 V



230 V

/ Optional extras see page 43

DOMETIC TL450

HEAVY-DUTY REFRIGERATION AND DEEP-FREEZE CONTAINER WITH TWO FACTORY PRESET FIXED TEMPERATURES (CAN BE SWITCHED)

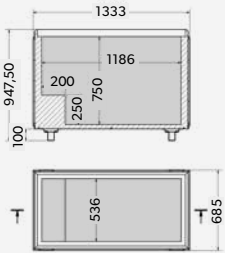

Capacity (l)	Storage volume: 393
Voltage	12 volts DC and 230 volts AC (24 volts DC on request)
Power consumption	300 watts
Temperature range	Fixed temperature +4 °C / -18 °C (at an ambient temperature of max. +38 °C)
Refrigerant	The cooling circuit contains the fluorinated greenhouse gas R 404a (245 g), CO ₂ equivalent: 0,961 t, GWP: 3922
Insulation	Polyurethane
System	DC: Compressor, AC: with built-in power supply
Material	Sheet steel housing
Dimensions (W x H x D)	1333 x 947,5 x 685 mm
Weight	150 kg
Quality features	Heavy-duty design, two fixed temperatures: +4 °C / -18 °C*, pallet feet for safe loading and unloading with fork-lifts; attachment points for safe storage on-board; transport rollers as accessories
Ref. No.	9103540406



PRESET FIXED TEMPERATURE CAN BE SWITCHED BETWEEN +4 °C / -18 °C (AT AN AMBIENT TEMPERATURE OF MAX. +38 °C)



12 V



230 V



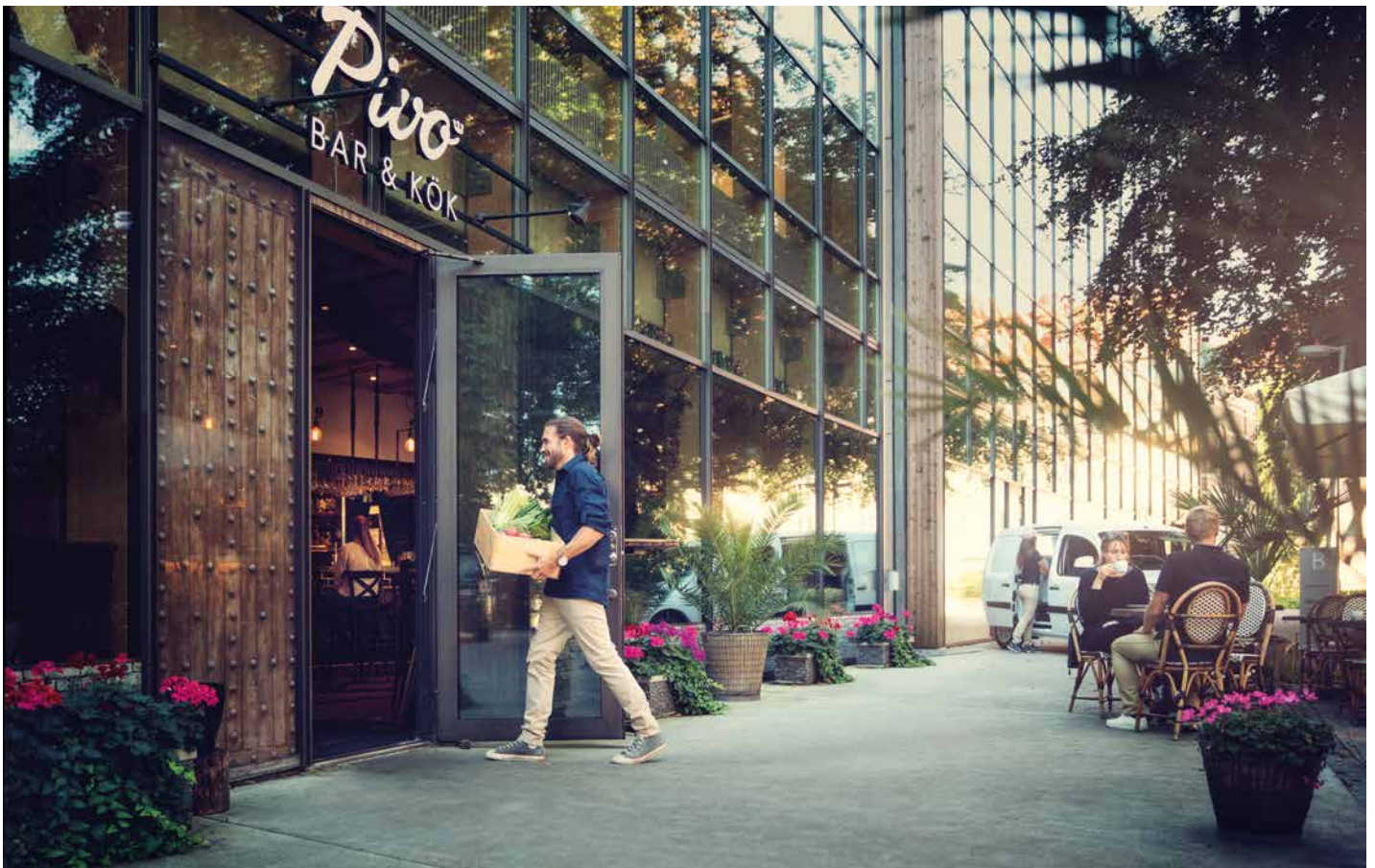

/ Optional extras see page 43



*At an external temperature of 32 °C.

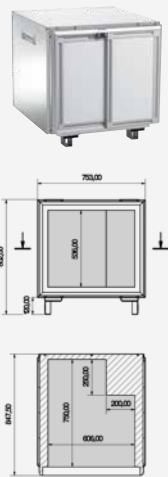



DOMETIC FO200 NC

HEAVY-DUTY REFRIGERATION CONTAINER WITH A FACTORY PRESET FIXED TEMPERATURE

	Capacity (l)	Storage volume: 188	 PRESET FIXED TEMPERATURE +4 °C (AT AN AMBIENT TEMPERATURE OF MAX. +38 °C)  12 V  230 V
	Voltage	12 volts DC and 230 volts AC (24 volts DC on request)	
	Power consumption	108 watts	
	Temperature range	Fixed temperature +4 °C (at an ambient temperature of max. +38 °C)	
	Refrigerant	The cooling circuit contains the fluorinated greenhouse gas R 134a (150 g), CO ₂ equivalent: 0,215 t, GWP: 1430	
	Insulation	Polyurethane	
	System	DC: Compressor, AC: with built-in power supply	
	Material	Sheet steel housing	
	Dimensions (W x H x D)	753 x 802 x 847,5 mm	
	Weight	110 kg	
Quality features	Heavy-duty design, one fixed temperature: +4 °C*, pallet feet for simple and safe loading and unloading with fork-lifts; attachment points for safe storage on-board; optional battery set for independent power supply; transport rollers available as accessories		
Ref. No.	9103540408		
/ Optional extras see page 43			

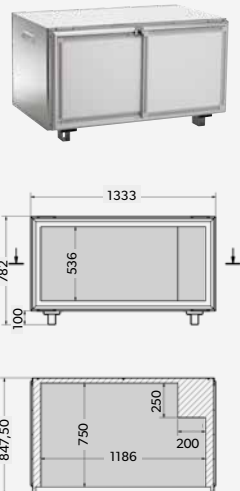
DOMETIC FO450 NC

HEAVY-DUTY REFRIGERATION CONTAINER WITH A FACTORY PRESET FIXED TEMPERATURE

	Capacity (l)	Storage volume: 393	 PRESET FIXED TEMPERATURE +4 °C (AT AN AMBIENT TEMPERATURE OF MAX. +38 °C)  12 V  230 V
	Voltage	12 volts DC and 230 volts AC (24 volts DC on request)	
	Power consumption	108 watts	
	Temperature range	Fixed temperature +4 °C (at an ambient temperature of max. +38 °C)	
	Refrigerant	The cooling circuit contains the fluorinated greenhouse gas R 134a (195 g), CO ₂ equivalent: 0,279 t, GWP: 1430	
	Insulation	Polyurethane	
	System	DC: Compressor, AC: with built-in power supply	
	Material	Sheet steel housing	
	Dimensions (W x H x D)	1333 x 782 x 847,5 mm	
	Weight	150 kg	
Quality features	Heavy-duty design, one fixed temperature: +4 °C*, pallet feet for simple and safe loading and unloading with fork-lifts; attachment points for safe storage on-board; optional battery set for independent power supply; transport rollers available as accessories		
Ref. No.	9103540409		
/ Optional extras see page 43			

DOMETIC COOLING CONTAINERS FLEXIBLE SOLUTION FOR LEASING VEHICLES AND MULTIPURPOSE VEHICLES

With our compressor cooling containers Dometic CoolFreeze FO 600 and FO 800 you can have a flexible solution for leasing vehicles, dual temperature for refrigerated vehicles or multipurpose vehicles. The spacious 600 or 800-litre containers are simply lashed to the cargo floor with straps or hooks. Energy for cooling comes from the 12-volt vehicle battery or a 230-volt mains supply.

For refrigerated transport we recommend the FO 800NC with a factory-preset fixed temperature of +4 °C. The FO 650 comes standard with two preset fixed temperatures. That means you can choose from two settings to suit the application at hand: +4 °C for refrigeration or -18 °C for deep-freezing. Another benefit of this retrofit solution: clean removal is possible anytime.

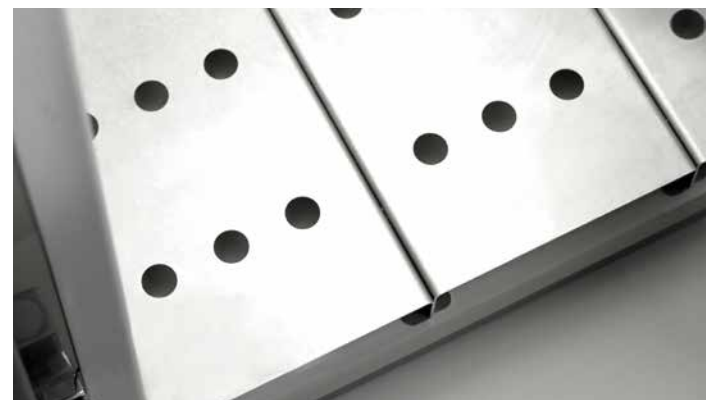

HEAVY-DUTY EQUIPMENT

Stainless steel hinges and locks

INTEGRATED AIR FLOW PANELS

Ensures a steady temperature distribution from bottom to top

DOMETIC FO650

HEAVY-DUTY REFRIGERATION CONTAINER WITH A FACTORY PRESET FIXED TEMPERATURE

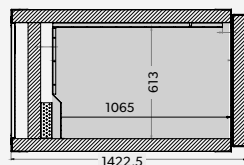
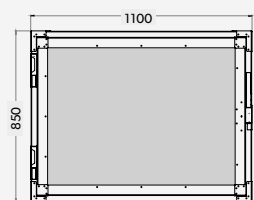

Capacity (l)	Storage volume: 607
Voltage	12 volts DC and 230 volts AC (24 volts DC on request)
Power consumption	300 watts
Temperature range	Fixed temperature +4 °C / -18 °C (at an ambient temperature of max. +38 °C)
Refrigerant	The cooling circuit contains the fluorinated greenhouse gas R 404a (210 g), CO ₂ equivalent: 0,824 t, GWP: 3922
Insulation	PU foam
System	Fully hermetic DC compressor and no frost air circulation system
Material	Fibre glass cabinet with stainless steel frame construction and stainless steel base
Dimensions (W x H x D)	1100 x 850 x 1422,5 mm
Weight	180 kg
Quality features	Innovative no frost air flow concept – reaches also the corners, high-quality fibre glass cabinet with stainless steel frame and stainless steel base, secure closing system – emergency opening from inside possible, suitable for most common van models, approved by leading logistic companies, green status-LED
Ref. No.	9600024342

/ Optional extras see page 43



PRESET FIXED TEMPERATURE CAN BE SWITCHED BETWEEN +4 °C / -18 °C (AT AN AMBIENT TEMPERATURE OF MAX. +38 °C)



12 V



230 V

DOMETIC FO800 NC

HEAVY-DUTY REFRIGERATION CONTAINER WITH A FACTORY PRESET FIXED TEMPERATURE

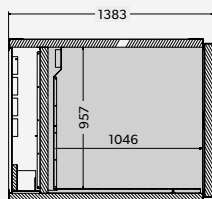
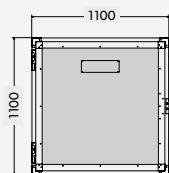

Capacity (l)	Storage volume: 605
Voltage	12 volts DC and 230 volts AC (24 volts DC on request)
Power consumption	300 watts
Temperature range	Fixed temperature +4 °C (at an ambient temperature of max. +38 °C)
Refrigerant	The cooling circuit contains the fluorinated greenhouse gas R 404a (175 g), CO ₂ equivalent: 0,250 t, GWP: 1430
Insulation	PU foam
System	Fully hermetic DC compressor and no frost air circulation system
Material	Fibre glass cabinet with stainless steel frame construction and stainless steel base
Dimensions (W x H x D)	1100 x 1100 x 1383 mm
Weight	121 kg
Quality features	Innovative no frost air flow concept – reaches also the corners, high-quality fibre glass cabinet with stainless steel frame and stainless steel base, secure closing system – emergency opening from inside possible, suitable for most common van models, approved by leading logistic companies
Ref. No.	9600002642

/ Optional extras see page 43



PRESET FIXED TEMPERATURE +4 °C (AT AN AMBIENT TEMPERATURE OF MAX. +38 °C)



12 V



230 V

DOMETIC FO850 NC

HEAVY-DUTY REFRIGERATION CONTAINER WITH A FACTORY PRESET FIXED TEMPERATURE

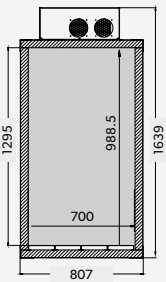

Capacity (l)	Storage volume: 788
Voltage	12 volts DC and 230 volts AC (24 volts DC on request)
Power consumption	300 watts
Temperature range	Fixed temperature +4 °C (at an ambient temperature of max. +38 °C)
Refrigerant	The cooling circuit contains the fluorinated greenhouse gas R 134a (175 g), CO ₂ equivalent: 0,25 t, GWP: 1430
Insulation	PU foam
System	Fully hermetic DC compressor and no frost air circulation system
Material	Fibre glass cabinet with stainless steel frame construction & stainless steel base
Dimensions (W x H x D)	807 x 1639 x 1017 mm (1137 with door)
Weight	113 kg
Quality features	Innovative no frost air flow concept – reaches also the corners, high-quality fibre glass cabinet with stainless steel frame and stainless steel base, secure closing system – emergency opening from inside possible, suitable for most common van models, approved by leading logistic companies, green status-LED
Ref. No.	9600024343



PRESET FIXED
TEMPERATURE +4 °C
(AT AN AMBIENT
TEMPERATURE OF
MAX. +38 °C)



12 V



230 V

/ Optional extras see page 43

DOMETIC FO1000 NC

HEAVY-DUTY REFRIGERATION CONTAINER WITH A FACTORY PRESET FIXED TEMPERATURE

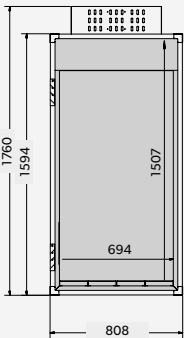

Capacity (l)	Storage volume: 901
Voltage	12 volts DC and 230 volts AC (24 volts DC on request)
Power consumption	300 watts
Temperature range	Fixed temperature +4 °C (at an ambient temperature of max. 38 °C)
Refrigerant	The cooling circuit contains the fluorinated greenhouse gas R 134a (175 g), CO ₂ equivalent: 0,25 t, GWP: 1430
Insulation	PU foam
System	Fully hermetic DC compressor and no frost air circulation system
Material	Fibre glass cabinet with stainless steel frame construction & stainless steel base
Dimensions (W x H x D)	808 x 1760 x 1135 mm (1208 with door)
Weight	123 kg
Quality features	Innovative no frost air flow concept – reaches also the corners, high-quality fibre glass cabinet with stainless steel frame and stainless steel base, secure closing system – emergency opening from inside possible, suitable for most common van models, approved by leading logistic companies
Ref. No.	9600002641



PRESET FIXED
TEMPERATURE +4 °C
(AT AN AMBIENT
TEMPERATURE OF
MAX. +38 °C)



12 V



230 V

/ Optional extras see page 43

OPTIONAL ACCESSORIES FOR REFRIGERATION AND DEEP-FREEZE CONTAINERS

In developing our refrigeration containers, we have taken into account many practical requirements – e.g. equipment for transporting with forklifts. Alternatively, you can replace the pallet feet with wheels. Or add a digital system to document temperature variations.

Choose what fits your application!



REFRIGERATION AND DEEP-FREEZE CONTAINERS	DT-08N THERMAL PRINTER	DT-23 ONE FACTORY PRESET FIXED TEMPERATURE	DT-24 BATTERY SET INCLUDING CHARGER	DT-25 WHEEL SET	DT-31 METAL PALLET	DT-32 24 VOLT DC SET EXTENSION
TL200	●	●*	●*	●		●*
TL300	●	●*	●*	●		●*
TL450	●	●*	●*	●		●*
FO200NC	●	●*		●		●*
FO450NC	●	●*		●		●*
FO650	●	●*				●*
FO800NC	●	●*		●		●*
FO850NC	●	●*			●	●*
FO1000NC	●	●*		●	●	●*

*Accessories only available ex works. A retrofit is not possible.



TESTO DT-07N

Temperature data logger as a single unit, without software. Software download from www.testo.com

Ref. No. 9103540007

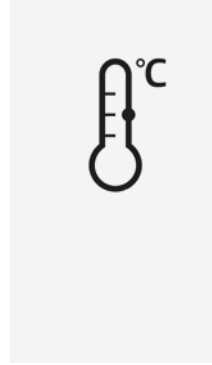

DT-23

Configuring a fixed temperature in the range from +4 °C to +25 °C according to customer requirements. Tolerance: ± 2 °C. Automatic heat & cool function. Test report included in the scope of supply.

Ref. No. 9103540428

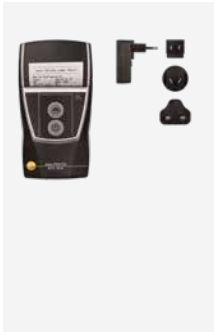

TESTO DT-08N

Thermal printer for displaying the temperature variation graphically (to be used in combination with DT-07N).

Ref. No. 9103540008



DT-24

Battery set including charger. For off-mains operation for up to 8 hours (at an external temperature of +32 °C). Only available as a factory-fitted option. 2 batteries with 55 Ah each.

Ref. No. 9103540411



DT-25

Wheel set (4x set) for safe and easy transport to the place of installation
Content: 2 fixed wheels, 2 movable wheels with parking brake, height: 127 mm

Ref. No. 9103540412



DT-31

4-way metal pallet (Euro size) screwed to the container to increase flexibility in use with a forklift truck. Increased overall height: 130 mm. 1200 x 800 x 130 mm (L x W x H)
Load capacity 1500 kg
For FO850NC and FO1000NC

Ref. No. 9600024929



DT-32

24 Volt DC set
Extension of reefer containers to 24 volt application.

Ref. No. 9600024930



MEDI AND



OP 1

CINE LABS

CUSTOMISED COOLING SOLUTIONS

MEDICINE AND LABS / REFRIGERATED MEDICINE CABINETS

DOMETIC DS AND HC SERIES MEDICINE CABINETS

SILENT ABSORPTION COOLING OR POWERFUL COMPRESSOR TECHNOLOGY

The ideal solution for storing vaccines, insulin and other heat-sensitive drugs safely at a temperature between 2 °C and 8 °C. The compartments enable you to keep the medicine arranged and grouped clearly. A digital thermometer monitors the internal temperature and stores the highest and lowest temperature for a defined control period.



230 V



+2 °C TO +8 °C



SILENT
DS SERIES

HC 302 +
HC 502 also
available as
DIN version

**CONSTANT
TEMPERATURE LEVEL**

**+5 °C FIXED POINT
TEMPERATURE
(±3 °C VARIATION)**

**AUTOMATIC
DOOR ALARM**

HEALTH-CARE REFRIGERATORS

THE APPLIANCES IN COMPARISON

You can choose between different cooling techniques and features:





- DS series with silent absorption cooling: for normal ambient temperatures, equipped with an external thermometer and plastic drawers (1/2 extension); replaceable door hinge
- HC series with powerful, energy-efficient compressor technology: equipped with integrated temperature display and high-quality, roll-out metal drawers with plastic front and 3/4 extension

PRODUCT BENEFITS

- Automatic alarm: audible warning if the door is open for more than 20 seconds
- Tall drawer fronts: keep warm air out when the door is opened
- Extra modules DT-02 (one fixed temperature) and DT-05 (extra heater) see page 30

HC-DIN devices have the same equipment as HC devices (see page 49) plus the following additional features:

- Optical and acoustic signal if temperature goes above or below set temperature
- Optical and acoustic signal in case of power failure for at least 12 hours thanks to integrated battery
- Potential-free contact (e.g., for remote maintenance)

	NOISELESS ABSORPTION COOLING		COMPRESSOR COOLING	
TECHNICAL DATA				
MODEL	DS 301 H	DS 601 H	HC 302 / HC 302D	HC 502 / HC 502D
Gross Capacity (litres)	27	53	33	49
Storage volume (litres)	23	51	29	43
Housing colour	White	White	White	White
Cooling technology	Absorption	Absorption	Compressor	Compressor
Temperature range (non-adjustable)	2–8 °C	2–8 °C	2–8 °C	2–8 °C
Dimensions (H x W x D, mm)	580 x 422 x 393	592 x 486 x 494	580 x 422 x 450	592 x 486 x 494
Power consumption (kWh/24 h)	0.86	1.05	0.42	0.44
Drawers (number)	3	3	3	3
Door lock	•	•	•	•
Digital thermometer with data memory	external	external	internal	internal
Variable door hinge	•	•	–	–
LED interior light	•	•	•	•

Features	DS series (Absorption Cooling)	HC series (Compressor Cooling)
	<ul style="list-style-type: none"> • Silent absorption cooling for normal ambient temperatures • External thermometer with min/max. memory • Plastic drawers with 1/2 extension and high, transparent front • Replaceable door hinge • Can be built-in (variable hinge not possible) 	<ul style="list-style-type: none"> • Powerful compressor cooling – safety under high ambient temperatures, extremely low energy consumption • Illuminated thermometer with min/max memory built into door • High-quality, roll-out metal drawer with 3/4 extension for especially well-arranged storage system • Can be built-in (variable hinge not possible) • Available accessories for HC 302 / HC 502: DT-02 (see page 30)

SILENT ABSORPTION REFRIGERATORS

Medicines, vaccines etc are safely stored in the DS series silent absorption refrigerators. The interior has a constant, even temperature that is monitored by an external thermometer. Practical drawers with high, transparent front provide convenient handling and minimal loss of refrigeration when opening.

Quality features: External thermometer with min/max memory, plastic drawers with 1/2 extension and high, transparent front, LED interior lighting, door lock, replaceable door hinge, can be built in (variable hinge not possible)

DOMETIC DS 301 H

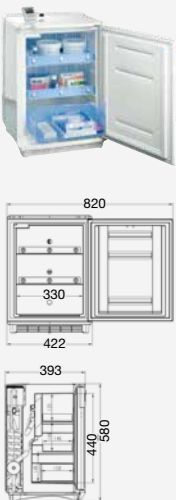
ABSORPTION REFRIGERATOR	
	Gross capacity approx. 27 litres
	Voltage 230 volts
	Average power consumption 65 watts
	Temperature range Fixed point temperature +5 °C, ±3 °C variation
	Insulation PU full foam insulation
	System Silent absorption refrigeration for normal interior temperatures
	Material Full-trim plastic housing with rear-wall cover
	Colour Housing: white; door: white
	Weight approx. 15 kg
	Exterior dimensions (H x W x D) 580 x 422 x 393 mm
Quality features External thermometer with min/max memory for monitoring the interior temperature, can be integrated (not with variable hinge), plastic drawers with 1/2 extension, LED interior lighting, door lock, replaceable door hinge	
Test marks e-approved (Automotive EMC Directive)	
Ref. No. 9600027080/UK 93600027083	



FIXED POINT TEMPERATURE
 +5 °C, ±3 °C VARIATION

DOMETIC DS 601 H

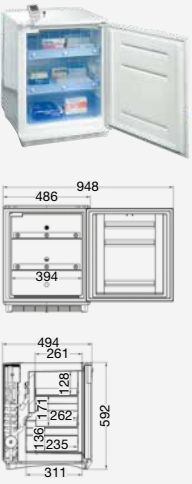
ABSORPTION REFRIGERATOR	
	Gross capacity approx. 53 litres
	Voltage 230 volts
	Average power consumption 85 watts
	Temperature range Fixed point temperature +5 °C, ±3 °C variation
	Insulation PU full foam insulation
	System Silent absorption refrigeration for normal interior temperatures
	Material Full-trim plastic housing with rear-wall cover
	Colour Housing: white; door: white
	Weight approx. 20 kg
	Exterior dimensions (H x W x D) 592 x 486 x 494 mm
Quality features External thermometer with min/max memory for monitoring of interior temperature, can be integrated (not with variable hinge), plastic drawers with 1/2 extension, LED interior lighting, door lock	
Test marks e-approved (Automotive EMC Directive)	
Ref. No. 9600027074	



FIXED POINT TEMPERATURE
 +5 °C, ±3 °C VARIATION





POWERFUL, ENERGY-EFFICIENT COMPRESSOR REFRIGERATORS

Also available as DIN version



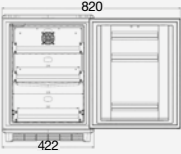

When needing to store medicine safely at high ambient temperatures, we recommend a refrigerator with a powerful compressor system. Our HC series devices have an integrated illuminated temperature display. High-quality roll-out metal drawers which can be extended to 3/4 of their depth offer well-organised storage. Quality features: Integrated thermometer with min/max memory, illuminated

temperature display, high-quality, roll-out metal drawers with 3/4 extension and plastic front, LED interior lighting, door lock, can be built in (variable hinge not possible). HC 302 / HC 502 optionally available as DIN 58345 compliant model versions (HC 302D / HC 502D). DIN-versions: Optical and acoustic signal in case of power failure for at least 12 hours thanks to integrated battery.

DOMETIC HC 302 / HC 302D

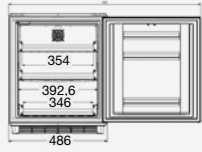
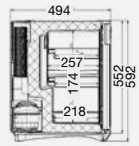
COMPRESSOR REFRIGERATOR			
  	Gross capacity approx. 33 litres	 <p>FIXED POINT TEMPERATURE +5 °C, ±3 °C VARIATION</p>  <p>HC 302D CERTIFIED ACCORDING TO DIN 58345</p>  <p>EXTRA MODULES DT-02 (ONE FIXED TEMPERATURE) AND DT-05 (EXTRA HEATER) SEE PAGE 30</p>	
	Voltage		230 volts
	Average power consumption		40 watts
	Temperature range		Fixed point temperature +5 °C, ±3 °C variation
	Refrigerant		The cooling circuit contains the fluorinated greenhouse gas R 134a (38 g), CO ₂ equivalent: 0.054 t, GWP: 1430
	Insulation		PU full foam insulation
	System		Powerful compressor cooling – even under high ambient temperatures
	Material		Full-trim plastic housing with rear-wall cover
	Colour		Housing: white; door: white
	Weight		approx. 17 kg
Exterior dimensions (H x W x D)	580 x 422 x 450 mm		
Quality features	Integrated thermometer with min/max memory, illuminated temperature display, high-quality roll-out metal drawers with 3/4 extension and plastic front, LED interior lighting, door lock		
Test marks	e-approved (Automotive EMC Directive)		
Ref. No.	HC 302: 9105204209 HC 302D: 9105204421/UK 9105204423		

DOMETIC HC 502 / HC 502D

COMPRESSOR REFRIGERATOR			
  	Gross capacity approx. 49 litres	 <p>FIXED POINT TEMPERATURE +5 °C, ±3 °C VARIATION</p>  <p>HC 502D CERTIFIED ACCORDING TO DIN 58345</p>  <p>EXTRA MODULES DT-02 (ONE FIXED TEMPERATURE) AND DT-05 (EXTRA HEATER) SEE PAGE 30</p>	
	Voltage		230 volts
	Average power consumption		40 watts
	Temperature range		Fixed point temperature +5 °C, ±3 °C variation
	Refrigerant		The cooling circuit contains the fluorinated greenhouse gas R 134a (38 g), CO ₂ equivalent: 0.054 t, GWP: 1430
	Insulation		PU full foam insulation
	System		Powerful compressor cooling – even under high ambient temperatures
	Material		Full-trim plastic housing with rear-wall cover
	Colour		Housing: white; door: white
	Weight		approx. 21 kg
Exterior dimensions (H x W x D)	592 x 486 x 494 mm		
Quality features	See HC 302 / HC 302D		
Test marks	e-approved (Automotive EMC Directive)		
Ref. No.	HC 502: 9105204215 HC 502D: 9105204425/UK 9105204427		

MOBILE, HYGIENIC, WELL-MADE IN EVERY DETAIL



Cooling or heating with $\pm 1\text{ }^{\circ}\text{C}$ accuracy: Dometic's innovative generation of refrigerator and warmer cabinets was specifically designed for use in emergency vehicles.

The interior temperature is limited at $+5\text{ }^{\circ}\text{C}$ or, respectively, $+37\text{ }^{\circ}\text{C}$ ($\pm 1\text{ }^{\circ}\text{C}$). This, combined with well thought-out details, qualifies the cabinets for other applications, too.



NO TAMPERING POSSIBLE

Digital temperature display (MH 07: red, MR 07: blue) in a stainless steel frame



TRANSPORT-PROOF

Catches that keep the door tightly closed even in inclined position



NO MIXING UP OF ITEMS

Well illuminated interior



INNER VALUES

Water drainage in the bottom







FAN

for an even temperature distribution



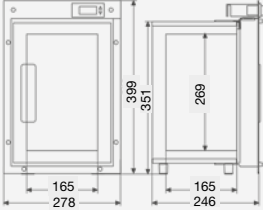

DOMETIC COOLMATIC MH 07

BUILT-IN HEATING CABINET WITH STAINLESS STEEL FRONT. FIXED POINT TEMPERATURE SET AT $+37\text{ }^{\circ}\text{C}$ ($\pm 1\text{ }^{\circ}\text{C}$)

	Gross capacity	approx. 7 litres	 +37 °C FIXED POINT TEMPERATURE ($\pm 1\text{ }^{\circ}\text{C}$)		
	Connection voltage	12 volts DC		 CERTIFIED ACCORDING TO DIN 75079	
	Average power consumption	approx. 15 to 20 watts			 12 V
	Temperature range	Fixed point temperature at $+37\text{ }^{\circ}\text{C}$ ($\pm 1\text{ }^{\circ}\text{C}$)			
	Refrigerant	The cooling circuit contains the fluorinated greenhouse gas R134a (45 g), CO ₂ equivalent: 0.064 t, GWP: 1430			
	Insulation	Polyurethane			
	System	12-volt heating resistor			
	Material	Door and flush-mount installation frame: stainless steel; Inner container: plastic			
	Colour	Front: silver. Interior: white			
	Weight	approx. 4.5 kg			
	Dimensions (W x H)	245 x 350 mm (installation space)			
	Quality features	Fixed point temperature set at $+37\text{ }^{\circ}\text{C}$ ($\pm 1\text{ }^{\circ}\text{C}$), optimum temperature distribution with additional, durable fan in the back wall of the interior, digital temperature display built into the stainless steel installation frame – no third party access possible, interior light, shelves with three heights, recessed door grip, door hinges and lock variable right / left			
Test marks	e-approved (Automotive EMC Directive)				
Ref. No.	9105204551				

DOMETIC COOLMATIC MR 07



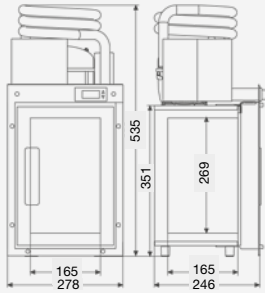

BUILT-IN COMPRESSOR REFRIGERATOR WITH STAINLESS STEEL FRONT. FIXED POINT TEMPERATURE SET AT +5 °C (±1 °C)

	Gross capacity	approx. 7 litres	
	Connection voltage	12 volts DC	
Average power consumption	approx. 36 watts		
Temperature range	Fixed point temperature at +5 °C (±1 °C)		CERTIFIED ACCORDING TO DIN 75079
Refrigerant	The cooling circuit contains the fluorinated greenhouse gas R 134a (45 g), CO ₂ equivalent: 0.064 t, GWP: 1430		
Insulation	Polyurethane		12 V
System	Fully hermetic compressor with integrated control electronics, low-voltage protection, electronic fuse / automatic reverse pole protection, dynamically ventilated wire tube condenser, foam-backed three sided rear panel vaporiser		
Material	Door and flush-mount installation frame: stainless steel; Inner container: plastic		COOLING UNIT CAN BE INSTALLED SEPARATELY
Colour	Front: silver. Interior: white		
Weight	approx. 10 kg		
Dimensions (W x D)	245 x 350 mm (installation space)		
Quality features	Fixed point temperature set at +5 °C (±1 °C), optimum temperature distribution with additional, durable fan in the back wall of the interior, digital temperature display built into the stainless steel installation frame – no third party access possible, interior light, shelves with three heights, recessed door grip, door hinges and lock variable right / left. For smaller space requirements, the unit can also be fitted at the side (right or left) of the model or at a distance of up to 1.5 m.		
Test marks	e-approved (Automotive EMC Directive)		
Ref. No.	9105204550		



DOMETIC COOLMATIC MRR 07

BUILT-IN COMPRESSOR REFRIGERATOR WITH STAINLESS STEEL FRONT. FIXED POINT TEMPERATURE SET AT +5 °C (±1 °C)

	Gross capacity	approx. 7 litres	
	Connection voltage	12 volts DC	
Average power consumption	approx. 36 watts		
Temperature range	Fixed point temperature at +5 °C (±1 °C)		CERTIFIED ACCORDING TO DIN 75079
Refrigerant	The cooling circuit contains the fluorinated greenhouse gas R 134a (45 g), CO ₂ equivalent: 0.064 t, GWP: 1430		
Insulation	Polyurethane		12 V
System	Fully hermetic compressor with integrated control electronics, low-voltage protection, electronic fuse / automatic reverse pole protection, dynamically ventilated wire tube condenser, foam-backed three sided rear panel vaporiser		
Material	Door and flush-mount installation frame: stainless steel; Inner container: plastic		
Colour	Front: silver. Interior: white		
Weight	approx. 10 kg		
Dimensions (W x D)	245 x 350 mm (installation space)		
Quality features	Fixed point temperature set at +5 °C (±1 °C), optimum temperature distribution with additional, durable fan in the back wall of the interior, digital temperature display built into the stainless steel installation frame – no third party access possible, interior light, shelves with three heights, recessed door grip, door hinges and lock variable right / left. The unit is mounted on the mounting plate.		
Test marks	e-approved (Automotive EMC Directive)		
Ref. No.	9600000771		

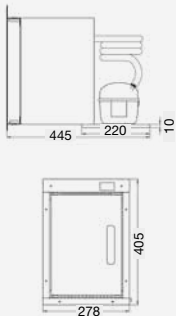







THERMOELECTRIC BUILT-IN BOXES

Compact, low-cost, safe: Our thermoelectric built-in boxes provide reliable cooling or heating for temperature-sensitive medicines and preparations. The interior temperature is limited to a factory-preset value (+5 °C in the cooler box, 39 °C for the warmer box). In ambulances, the small 2.5 litre units fit perfectly into the drawer where they can be permanently wired to prevent theft.

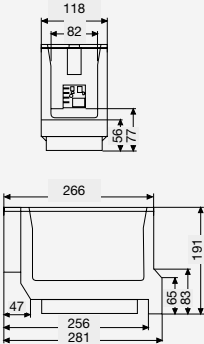

DOMETIC TROPICOOOL TB W203

THERMOELECTRIC BUILT-IN COOLER	TB W203 COOLING	TB W203 HEATING		
 	Gross capacity	approx. 2.5 litres		
	Connection voltage	12 volts DC		
	Average power consumption	30 watts, depending on ambient temperature		
	Insulation	Polyurethane		
	System	Maintenance free thermoelectrics, aluminium heat exchanger with dynamic air circulation, low-voltage protection with battery monitor (cut-off at 11.7 volts; cut-in at: 12.7 volts)		
	Material	Exterior: styrofoam. Interior: aluminium		
	Weight	approx. 1.5 kg		
	Temperature range	Interior temperature limited at +5 °C by an electronic circuit, reliable cooling up to 20 °C below the ambient temperature	Interior temperature limited at +39 °C by an electronic circuit, reliable heating up to 30 °C above the ambient temperature	 <p>COOLING UP TO 20 °C BELOW AMBIENT TEMPERATURE</p>  <p>HEATING UP TO 30 °C ABOVE AMBIENT TEMPERATURE</p>
	Quality features	Permanent (theft-proof) installation in a drawer, cabinet or worktop, practical fold-up lid, ON/OFF switch with status indication		
	Test marks	e-approved (Automotive EMC Directive)		<p>DOES NOT MEET THE REQUIREMENTS OF DIN 75079</p>  <p>12 V</p>
Ref. No.	960000490	9103540147		



SPECIAL SOLUTION FOR VETERINARY MEDICINE

A certified special solution for veterinary vehicles: The factory pre-set fixed point temperature of +5 °C is reliably maintained with an accuracy of ± 1 °C. It allows heat-sensitive products and samples to be transported without compromising the quality.



DOMETIC COOLMATIC CRD 50S

COMPRESSOR REFRIGERATOR DRAWER WITH STAINLESS STEEL FRONT

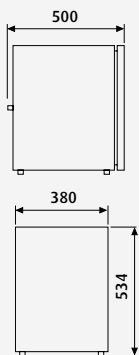

Capacity	approx. 38.5 litres
Connection voltage	12/24 volts DC
Average power consumption	approx. 40 watts
Temperature range	Fixed point temperature set at +5 °C (± 1 °C)
Refrigerant	The cooling circuit contains the fluorinated greenhouse gas R 134a (38 g), CO ₂ equivalent: 0.054 t, GWP: 1430
Insulation	PU full foam insulation
System	Fully-hermetic compressor with integrated control electronics, low-voltage protection, electronic fuse/automatic reverse pole protection, mechanical, continuously variable thermostat
Material	Body: coated metal frame, Inner containers: plastic, Fittings: stainless steel, Door: stainless steel (V4A)
Colour	Housing: black; Door: stainless steel
Weight	approx. 20 kg
Quality features	Optimum temperature distribution thanks to numerous integrated condensers in the interior, condensation water drains in the floor and rear panel, door lock with double action (close/ventilate)
Ref. No.	9103540374
/ Optional extras	
Standard installation frame	9105305676
Flush-mount installation frame	9105305671



+ 5 °C FIXED POINT TEMPERATURE (± 1 °C)



12/24 V

MILK- BEVERAGE





AND COOLERS







SPACE-SAVING COOLING SOLUTIONS FOR MILK AND MORE

Cappuccino, café latte, latte macchiato or a simple espresso – the fully-automated coffee machine gives customers what they ask for. Practical equipment for keeping milk fresh is available from cooling specialist Dometic.

The Dometic MyFridge products offer space-saving cooling solutions which were especially developed for cafés, restaurants and bistros.

With the compact models MyFridge MF 05M / MF 1M, the milk is filled in dishwasher-safe glasses and then cooled down in the device. In the MyFridge MF 5M mini-fridge, it is drawn directly from the bottle or tetrapack. We recommend the Dometic DW 6 as an elegant bar refrigerator for fizzy water and soft drinks.

DOMETIC MYFRIDGE MF 05M / MF 1M

MILK COOLER FOR AUTOMATED COFFEE MACHINES		MF 05M	MF 1M	
 MF 05M  MF 1M	Gross capacity	0.5 litres	1.0 litres	 TEMPERATURE RANGE UP TO 22 °C BELOW AMBIENT TEMPERATURE  100 – 240 V AC
	Voltage	100 – 240 V AC with power supply unit		
	Power consumption	Max. 20 watts		
	Temperature range	Cooling down to 22 °C below ambient temperature, temperature limiter at +1 °C		
	Insulation	PU full foam insulation		
	System	Wear-free thermo-electrics, powerful fan for continuous operation		
	Material	ABS		
	Colour	Silver/black		
	Weight	0.9 kg	1.7 kg	
	Dimensions (W x H x D)	110 x 180 x 145 mm	150 x 215 x 190 mm	
Quality features	0.5 litre milk glass, 20 cm milk hose and power supply unit	1.0 litre milk glass, 20 cm milk hose and power supply unit		
Test marks	TÜV/GS, e-certified (Automotive EMC Directive)			
Ref. No.	9600000596	9600000597		

DOMETIC MYFRIDGE MF 5M

MILK COOLER FOR AUTOMATED COFFEE MACHINES/MINI REFRIGERATOR

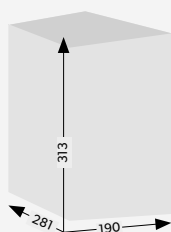

Gross capacity	5 litres
Voltage	230 V AC with integrated power adapter
Power consumption	Max. 33 watts
Temperature range	In cooling mode: up to 20 °C below the ambient temperature, temperature limit at +1 °C. In heating mode: temperature limit at +65 °C
Insulation	PU full foam insulation
System	Wear-free thermo-electrics, powerful fan for continuous operation
Material	ABS
Colour	Silver
Weight	3.3 kg
Dimensions (W x H x D)	190 x 313 x 281 mm
Quality features	Internal lighting, for up to two 1 litre milk pouches, lockable openings for milk hose, both sides; grid divider, 40 cm milk hose
Test marks	TÜV/GS, e-certified (Automotive EMC Directive)
Ref. No.	960000598



TEMPERATURE RANGE UP TO 20 °C BELOW AMBIENT TEMPERATURE



230 V AC

FOR AUTOMATED COFFEE MACHINES WITH SELF-PRIMING CAPPUCCINO NOZZLE

/ Optional extras

Connection cable	9600006608
Cap outer, chrome	40-126-03ABNNA
Cap inner, white	40-126-02AB9001

DOMETIC DW 6

THERMOELECTRIC DRINKS REFRIGERATOR

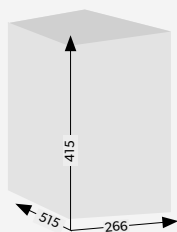

Gross capacity	20 litres
Voltage	12 V DC and 220 – 240 V AC / 50/60 Hz
Power consumption	36 W at 12 V DC 43 W at 230 V AC, 13 W at 230 V AC (Eco mode)
Temperature range	+5 °C to +20 °C, cooling performance up to 16 °C below ambient temperature
Insulation	Polyurethane
System	3 A Peltier system, double fan
Material	ABS
Colour	White
Weight	7.6 kg
Dimensions (W x H x D)	266 x 415 x 515 mm
Quality features	Electronic thermostat with digital temperature display, continuous temperature selection, transparent door, safe magnetic lock, 3 shelves, interior lighting can be switched on/off, drip tray for condensation water
Test marks	TÜV/GS, e-certified (Automotive EMC Directive)
Ref. No.	9105330356



TEMPERATURE RANGE UP TO 16 °C BELOW AMBIENT TEMPERATURE



220 – 240 V AC



12 V DC



ENERGY CLASS





RATED LING



REFRIGERATION WITHOUT ATTACHING TO THE ROOF

ADAPTED TO FREIGHT AND VEHICLE

The transport of temperature-sensitive freight is a demanding logistic task subject to strict legal regulations. It calls for a vehicle that is equipped to take perishable foodstuffs, medicines or blood donations from one place to another with one-degree accuracy. The modular Dometic Frigo system provides highly reliable cooling solutions for all commonly used refrigerated vehicles. The entire refrigeration system is integrated in the vehicle where it takes up little space – and without the roof-mounted structure you typically have with other manufacturers' systems.

It takes just a few easy steps to create a customised precision cooling system. You start by specifying the type of vehicle, the size of the load compartment and the required temperature conditions. We then put together the modules to suit your specifications. If required, we add optional features such as a stationary cooling system to be operated from the control panel.

ATP
+ DIN 8958
certified
according to require-
ments of the HACCP
guidelines.



Evaporator module

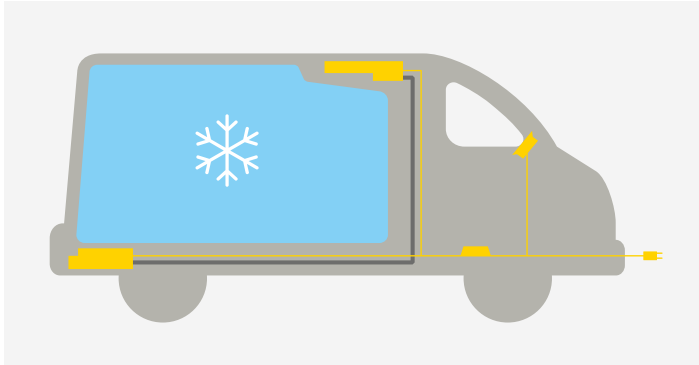

CERTIFIED REFRIGERATION FOR RELIABLE COLD CHAIN MANAGEMENT

Companies transporting foodstuffs or other temperature-sensitive products have to meet strict legal requirements. They are responsible for ensuring that the cold chain is maintained throughout the product's way to the consumer. No problem – Dometic Frigo cooling systems for refrigerated vehicles are 100 % reliable. Our systems are ATP-approved and certified to DIN 8958, a standard regulating the performance and functioning of cooling systems for thermally insulated means of transportation. Customers can be sure they can transport their sensitive freight safely and reliably at all times.



STAND-BY COOLING OPTION FOR DOMETIC FRIGO

The optional stand-by cooling kit optimises the logistic workflow. The vehicle can be loaded or remain loaded overnight so as to be ready in the morning to get on its way. There is no need to store the goods temporarily in a stationary cooling room. The compressor of the stand-by cooling kit is installed in the driver's cab underneath the seat; a 230 V external socket for connecting the system is built into the front bumper. As the cooling components of the installation are also supplied with on-board current in stationary mode, we have added a high-quality IUOU charger which ensures the vehicle battery is properly charged.

FULLY INTEGRATED COOLING – NO ROOF-MOUNT STRUCTURE

Dometic Frigo refrigeration systems give you the unique benefit of fully integrated installation. The evaporator unit is fitted to the ceiling of the cargo compartment in a space-saving manner. It's never in the way – neither during loading and unloading, nor during clean-up. Unlike with other manufacturers' systems, there's no roof-mounted structure. **That means:**

- No problems with headroom restrictions, e.g. in underground car parks
- Safer driving even in tricky situations, because the vehicle's centre of gravity remains unchanged
- No roof cut-out required – the chassis' stability and anti-corrosion properties are preserved
- No impairment of the vehicle's appearance and aerodynamics



HOT GAS DEFROSTING AS STANDARD OR OPTIONAL

Problems with long idle times when the evaporator is iced and needs to be thawed? Simply activate the Dometic Frigo hot gas defrosting system to get your vehicle back on the road in no time at all. It heats up the refrigerant between the compressor and evaporator and thaws the evaporator quickly, so it can work with full efficiency again.

Hot gas defrosting is included as standard on Dometic Frigo DC systems, but optional on the Dometic Frigo version.

NEW! DOMETIC FRIGO DC – FULLY INTEGRATED ELECTRICAL REFRIGERATION SYSTEM

HIGH FLEXIBLE TO VEHICLE SETUP





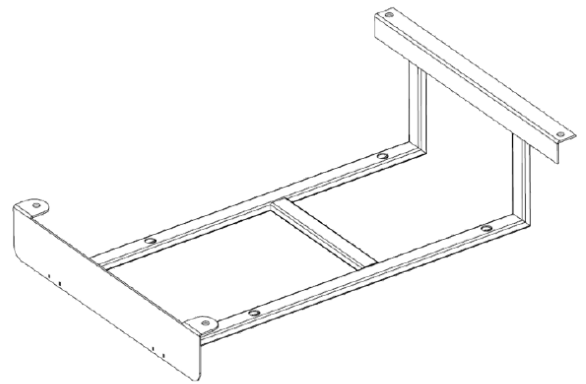

Today's compact van models offer little space for retrofitting a transport cooling systems. Quite often, it is impossible to integrate a belt-driving compressor in the engine compartment. The new generation Dometic Frigo DC systems solve this problem in a smart way. The compressor and the condenser are combined in a compact unit which is fitted in the spare wheel compartment. Like with all Dometic Frigo systems, the evaporator is mounted to the ceiling of the cargo hold.



DOMETIC FRIGO DC ADAPTER KITS FOR FAST AND EASY INSTALLATION

Our vehicle-specific Dometic Frigo DC adapter kits allow fast and easy installation of the compressor-condenser unit. Available for the most common vans. Contact your local dealer for more information.

DRIVING MODE COOLING PERFORMANCE

NEW! Dometic Frigo DC	30 °C Ext  			Air flow volume m ³ /h	Power consumption A	Dimensions Evaporator mm (W/H/D)	Total weight system kg
	Driving cooling						
	0 °C	+7 °C	+12 °C				
 DC 2500	1,030 W	1,325 W	1,565 W	780	68*	660 x 157 x 500	43
 DC 3500	1,125 W	1,445 W	1,670 W	1,140	85*	900 x 157 x 500	47
Refrigerant	R 134a						

Vehicle requirements: the vehicle must have minimum a 125 A alternator and a 90 A/h battery.
(Data for driving mode, stationary mode varies) *For outside temperature 30 °C and 0 °C inside temperature (according ATP)

DOMETIC FRIGO DC – THE SMARTEST AND EASIEST COOLING SYSTEM

- Combined compressor and condenser unit fitted in the spare wheel compartment giving faster and easier installation
- Variable speed compressor giving constant temperature control, higher performance and lower power consumption
- As no installation is required in the engine compartment it can be fitted to most vehicle
- Easy to service and maintain – less components, beltless compressor
- Integrated hotgas defrost function (serial)
- Intelligent compressor control unit which controls the RPM of the compressor and condenser fan according available energy (battery protection) and cooling performance requirement.
- Patent checked Power Management
- Approved according to automotive standards
- Easy to upgrade with stand-by cooling (battery charger and cable kit)

For detailed information about the Dometic Frigo modular system, please refer to the Dometic Frigo price and programme overview.

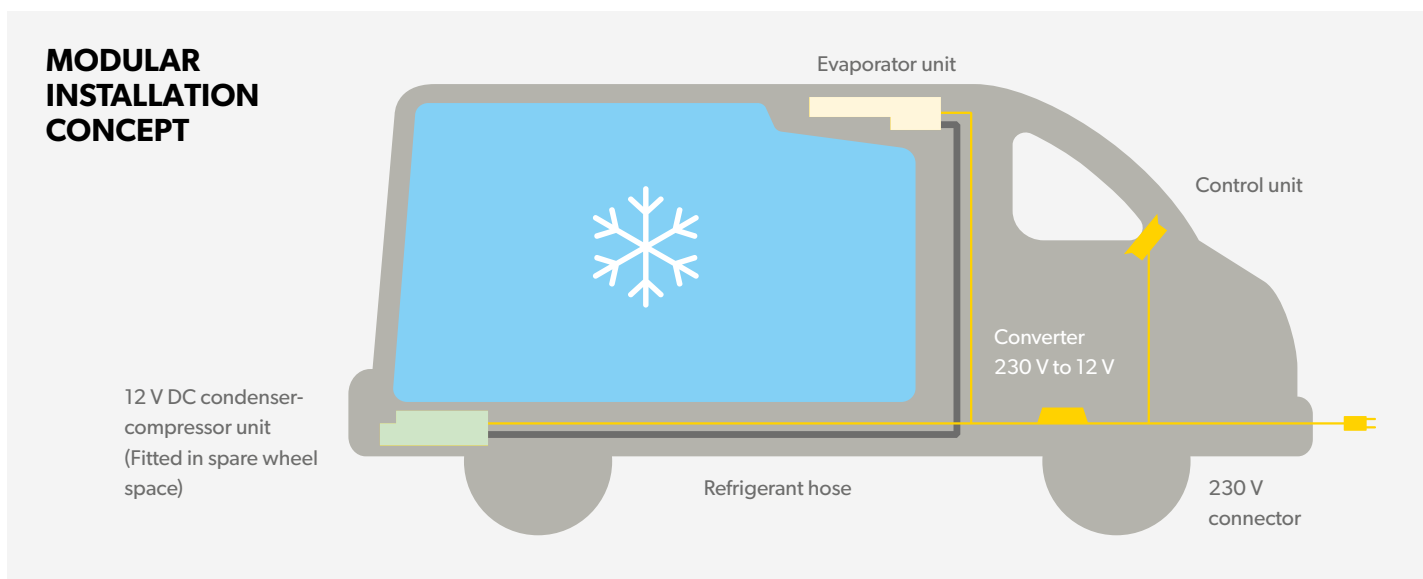

DOMETIC FRIGO DC OVERVIEW

EVAPORATOR DC 2500

COMPRESSOR-CONDENSER UNIT

HOSE, 4 M

OPTIONAL

VEHICLE ADAPTER KIT, STAND-BY KIT

EVAPORATOR DC 3500

COMPRESSOR-CONDENSER UNIT

HOSE, 6 M

OPTIONAL

VEHICLE ADAPTER KIT, STAND-BY KIT

DOMETIC FRIGO – BELT DRIVEN SYSTEM



Dometic Frigo refrigeration systems comprise several components, some of which are available as options. The modular concept allows easy customising for refrigerated and deep-freeze applications. Reliable cooling at constant temperatures can be achieved for load compartment volumes up to 18 m³. Regardless of whether it's long distance or local distribution, continuous cooling is guaranteed at all times.

You start with selecting the right size of evaporator, then you add the matching condenser and compressor. All in all, it will take only 8 to 12 hours to install the three basic components.

Our tip for deep-freeze applications

The Dometic Frigo DC kit includes all special components you need: hot gas defrosting for the evaporator and condensation drain, a low-pressure switch, and an oil separator.



DRIVING MODE – REFRIGERATION R 134A

Dometic Frigo	30 °C Ext  			Air flow volume	Power consumption
	0 °C	+ 6 °C	+ 12 °C		
	Driving cooling			m ³ /h	A
2500	1,752 W	2,107 W	2,524 W	780	22 A
3500	2,385 W	2,888 W	3,452 W	1,140	27 A
4500	2,454 W	3,051 W	3,589 W	1,560	31 A
Refrigerant	R 134a				

(Data for driving mode, stationary mode varies)

For cargo rooms up to 18 m³

DRIVING MODE – DEEP-FREEZE R 404A

Dometic Frigo	30 °C Ext  			Air flow volume	Power consumption
	0 °C	-10 °C	-20 °C		
	Driving cooling			m ³ /h	A
2500	2,394 W	1,797 W	1,034 W	780	22 A
3500	2,496 W	2,016 W	1,334 W	1,140	27 A
4500	2,567 W	2,062 W	1,283 W	1,560	31 A
Refrigerant	R 404a				

(Data for driving mode, stationary mode varies)

MODULAR SYSTEM FOR EASY CUSTOMIZING

- Internal assembly of the evaporator – no impact on the appearance or the aerodynamic properties of the vehicle
- Nothing on the roof – no risk of damage when driving into underground car parks
- Safer when having to make sudden movements as the vehicle's centre of gravity is not changed

- No need to cut into the roof trusses or sheet panel – the chassis' torsional stability and anti-corrosion properties are preserved

For detailed information about the Dometic Frigo modular system, please refer to the Dometic Frigo price and programme overview.

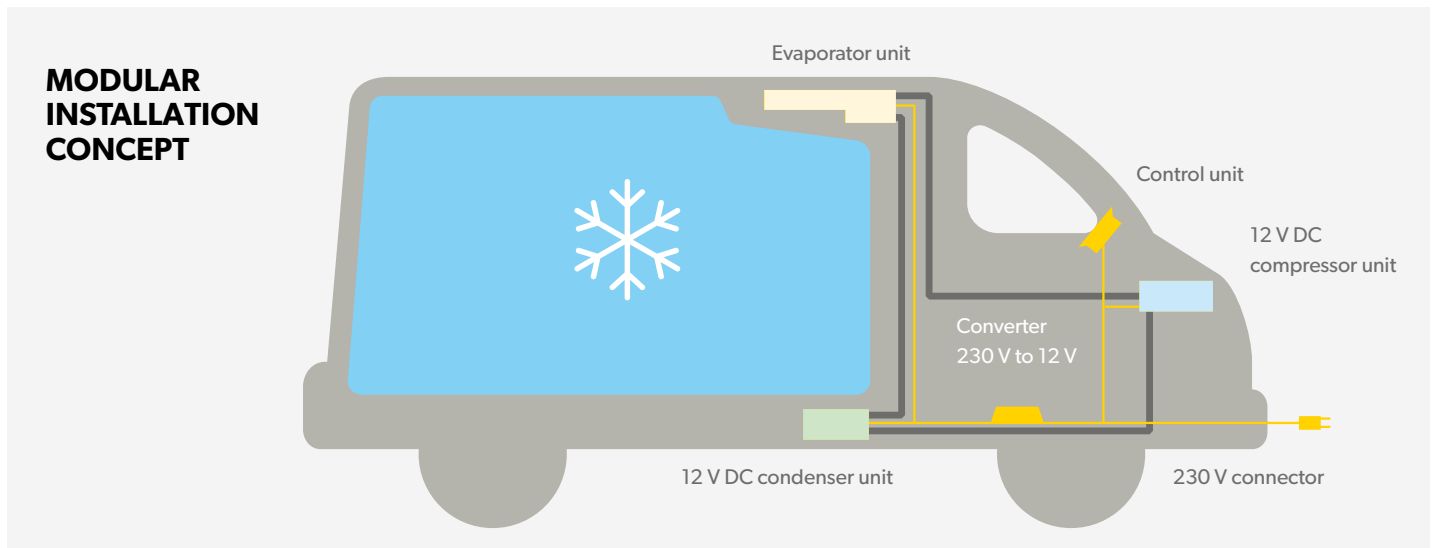

COMPONENTS CAN BE COMBINED FOR ANY APPLICATION

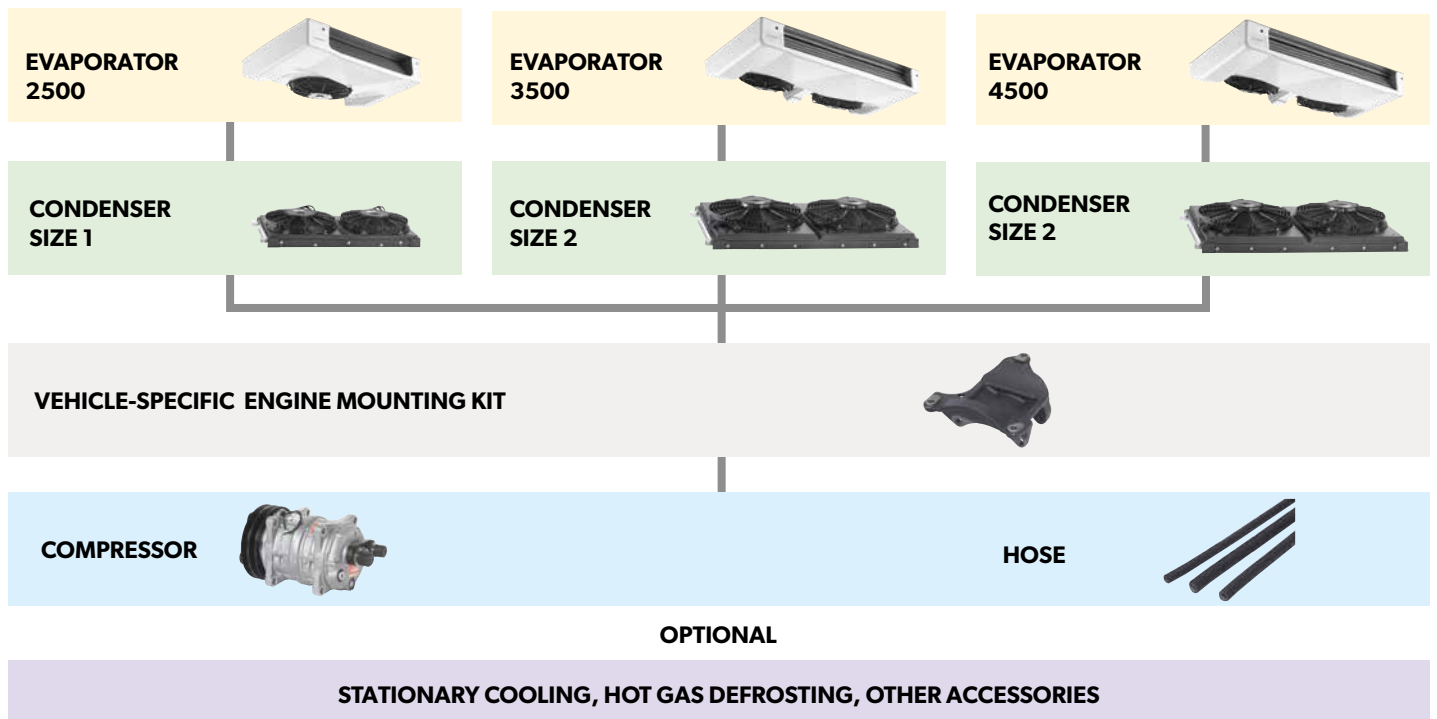

PRODUCT SELECTION

Operation performance according to ATP regulations with 3 door openings per hour at 30 °C outside temperature

NEW
Dometic Frigo
DC 2500

NEW
Dometic Frigo
DC 3500

Capacity
cargo room

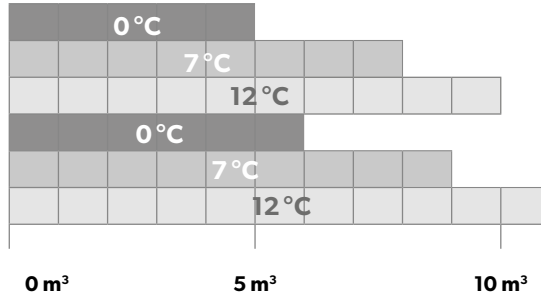

R134a

- 12 °C
- 7 °C
- 0 °C

Specifications for R134a: k-value = 0.4 W (m² K) with 3 door openings of 3 minutes each per hour, ambient temperature 30 °C, relative air humidity 60% (DIN 1815)

Dometic Frigo 2500
Dometic Frigo 3500
Dometic Frigo 4500

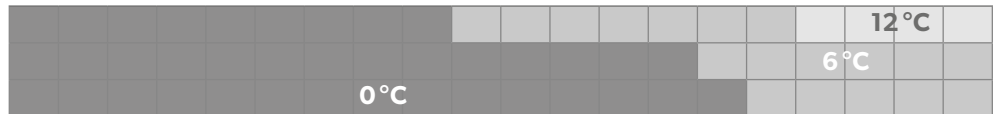

Dometic Frigo 2500
Dometic Frigo 3500
Dometic Frigo 4500

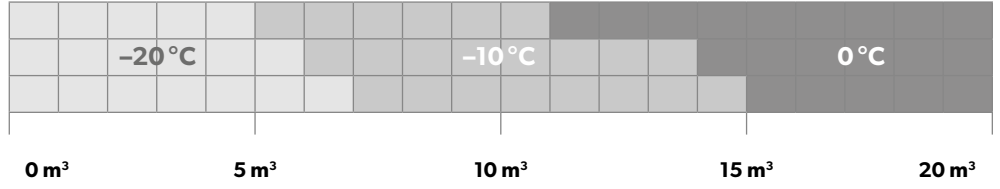

- R134a**
- 12 °C
 - 6 °C
 - 0 °C
- R404a**
- 0 °C
 - -10 °C
 - -20 °C

Specifications for R134a: k-value = 0.7 W (m² K) with 3 door openings of 3 minutes each per hour, ambient temperature 30 °C, relative air humidity 60% (DIN 1815)
Specifications for R404a: k-value = 0.4 W (m² K) with 3 door openings of 3 minutes each per hour, ambient temperature 30 °C, relative air humidity 60% (DIN 1815)

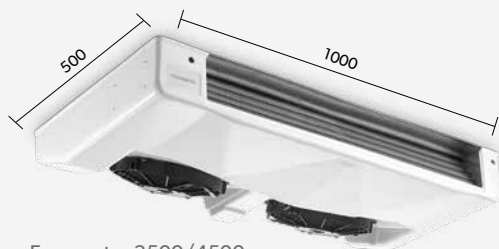

Evaporator 3500/4500

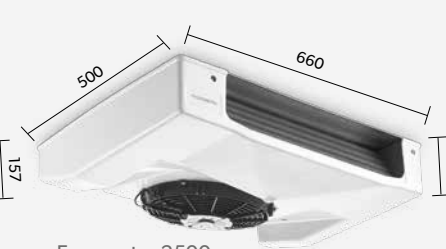

Evaporator 2500



Dometic Frigo DC Control unit
(Dometic Frigo DC only)



Condenser 3500/4500



Condenser 2500



Dometic Frigo DC Compressor-condenser (Dometic Frigo DC only)



INFO

The Dometic Frigo control unit displays when service is due. The cooling system will keep running, though. The calculation of the operating hours is based on the time the compressor is in operation. Service is due after the first 100 operating hours after the cooling system's initial start-up, and then every 1,000 operating hours.

UNIQUE TECHNICAL DETAILS DOMETIC FRIGO EXCELS WITH QUALITY

Performance, efficiency, durability, ease of installation and ease of maintenance: these are the requirements to be met by the designers of fully integrated cooling systems. Here are just a few technical details where Dometic Frigo systems make a difference.

MULTI-POINT REFRIGERANT INJECTION

Dometic Frigo systems owe their excellent cooling performance to a multi-point injection system and the use of evaporators with optimised capacity. The multi-point injection system ensures that the refrigerant is evenly distributed in the evaporator. This, in turn, results in a homogenous evaporation process and improves the cooling performance.



Optimised cooling: the multi-point injection system on the evaporator improves the distribution of the refrigerant.

FILTER DRIER WITH SIGHT GLASS

Another beneficial detail is the filter drier with the integrated sight glass, which makes it easy to monitor the fill level and condition of the refrigerant. A single glance on the sight glass is enough to know when the drier needs to be replaced. Damage to the system or downtimes can be effectively avoided. (Dometic Frigo only)

SPLASH-PROOF COMPONENTS

Quality is also the hallmark of the Stand-by cooling system. Dometic is the only manufacturer to offer a splash-proof 230-volt connection to be fitted on the bumper, a patented solution from DEFA.



Optimised check-up: the sight glass on the filter drier allows you to monitor the cooling system (Dometic Frigo only)



COOLING



G UNITS





COOLING UNITS IN THREE PERFORMANCE CATEGORIES

PROFESSIONAL SOLUTIONS FOR ALL INSTALLATION CONDITIONS

Refrigerated storage is required in market stalls, food trucks, emergency service vehicles and other special applications. Quite often, however, there's simply no space to spare for it. The alternative is to use the available storage space. With components from the Dometic ColdMachine series you can convert compartments, drawers and all types of containers into customised refrigeration solutions.

The range includes cooling units in three performance categories—all with power-regulated high-tech compressors and complementary evaporators in various shapes and sizes.



DOMETIC COLDMACHINE SERIES 50

Entry-level units at a great price

- Designed for small refrigerator capacities (up to approx. 130 litres) and for use in normal ambient temperatures
- Equipped with a power-regulated compressor
- Two air-cooled units of different body shapes
- Three evaporator types each designed to precisely match the compressor performance
- Corrosion-resistant stainless steel mounting plate
- Impeccable operation in inclined position

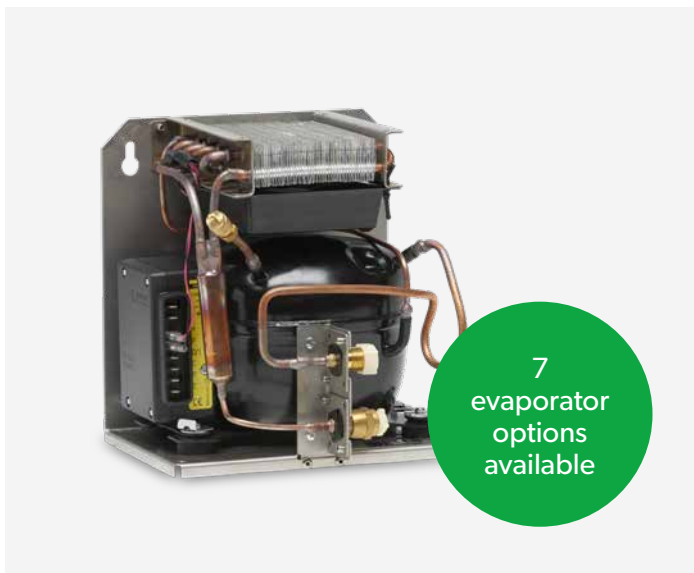

DOMETIC COLDMACHINE SERIES 80

Professional units for individual cooling comfort

- Designed for small and medium refrigerator capacities (up to approx. 250 litres) and for use in normal ambient temperatures
- Equipped with a power-regulated compressor
- Three air-cooled units of different body shapes
- Seven evaporator types and one cold accumulator with automatic programme controller, each designed to precisely match the compressor performance
- Corrosion-resistant stainless steel mounting plate
- Impeccable operation in inclined position

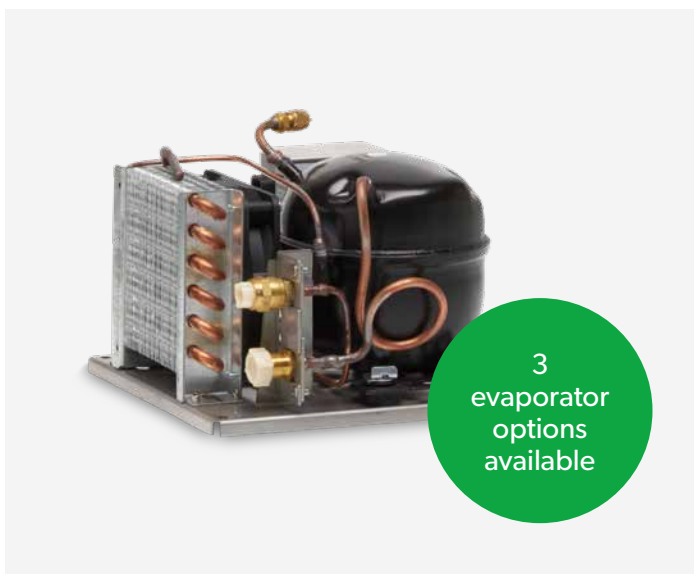



DOMETIC COLDMACHINE SERIES 90

Professional units for highest demands

- Designed for extra-large refrigerator capacities (up to approx. 400 litres), for deep-freeze cooling (up to approx. 200 litres) and for use in hot ambient temperatures
- Equipped with a power-regulated high-performance compressor (25 % more cooling power)
- Three air-cooled units of different body shapes
- Three evaporator types and one cold accumulator with automatic programme controller, each designed to precisely match the compressor performance
- Corrosion-resistant stainless steel mounting plate
- Impeccable operation in inclined positions
- With AEO electronics (Adaptive Energy Optimiser)

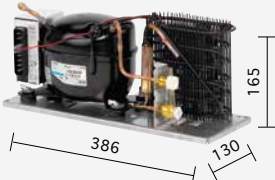
DOMETIC COLDMACHINE 54 / 55

COOLING UNITS	COLDMACHINE 54	COLDMACHINE 55	
	Cooling capacities	130 litres max. normal refrigeration with direct evaporators, 100 litres max. with cold accumulators	
	Voltage	12 / 24 V DC	
	Refrigerant	The cooling circuit contains the fluorinated greenhouse gas R 134a (35 g), CO ₂ equivalent: 0.050 t, GWP: 1430	
	System	Fully hermetic compressor with control electronics and integrated low-voltage protection, low-voltage cut-off, electronic reverse pole protection, dynamically ventilated wire tube condenser, self-sealing valve couplings	
	Dimensions (W x H x D)	386 x 165 x 130 mm	220 x 160 x 220 mm
	Weight (kg)	6	6.5
	Quality features	Suitable for floor mounting, corrosion-resistant stainless steel mounting plate	
	Ref. No.	9105306623	9105306624
	/ Optional extras		
	Mains adapter MPS 35, 110 – 240 V › 24 V		9600000445
	Mains adapter EPS 100, 230 V › 24 V		9600000440
			 <p>SUITABLE FOR SOLAR OPERATION</p> <p>WITH CORROSION-RESISTANT STAINLESS STEEL MOUNTING PLATE</p>

DOMETIC COLDMACHINE VD-01

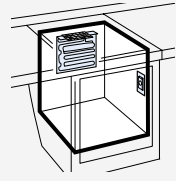
L-EVAPORATOR FOR SERIES 50			
	Cooling capacities (l) with 35 mm PU insulation with 50 mm PU insulation	max. 80 max. 100	
	Power input (approx. watts)	35	
	Current consumption (Ah/h) with 35 mm PU insulation with 50 mm PU insulation	1.46 1.17	
	System	Standard, L-shape evaporator for horizontal and vertical installation, self-sealing valve couplings, flexible connection pipe approx. 2 m, continuously variable thermostat (for external installation, with blue turning dial and LED indicator, white plastic housing), electric supply cord approx. 3 m	
	Dimensions (W x H x D)	300 x 270 x 110 mm	
	Weight (kg)	1.5	
	Ref. No.	9105306625	
			<p>THERMOSTAT WITH LED INDICATOR</p> 

DOMETIC COLDMACHINE VD-02

PLATE EVAPORATOR FOR SERIES 50

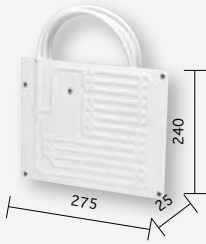

Cooling capacities (l) with 35 mm PU insulation with 50 mm PU insulation	max. 30
	max. 50
Power input (approx. watts)	35
Current consumption (Ah/h) with 35 mm PU insulation with 50 mm PU insulation	1.31
	1.02
System	Standard, plate evaporator for horizontal and vertical installation, self-sealing valve couplings, flexible connection pipe approx. 2 m, continuously variable thermostat (for external installation, with blue turning dial and LED indicator, white plastic housing), electric supply cord approx. 3 m
Dimensions (WxHxD)	275 x 240 x 25 mm
Weight (kg)	1
Ref. No.	9105306627

DOMETIC COLDMACHINE VD-07



O-EVAPORATOR FOR SERIES 50



Cooling capacities (l) with 35 mm PU insulation with 50 mm PU insulation	max. 100
	max. 130
Power input (approx. watts)	35
Current consumption (Ah/h) with 35 mm PU insulation with 50 mm PU insulation	1.46
	1.17
System	Standard O-evaporator for horizontal or vertical installation, self-sealing valve couplings, flexible connection pipe approx. 2 m, continuously variable thermostat (for external installation, with blue turning dial and LED indicator, white plastic housing), electric supply cord approx. 3 m
Dimensions (WxHxD)	255 x 210 x 90 mm
Weight (kg)	1.5
Ref. No.	9105306628

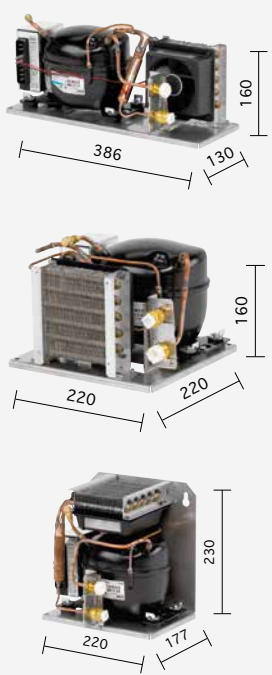

DOMETIC COLDMACHINE 84 / 85 / 86

COOLING UNITS	COLDMACHINE 84	COLDMACHINE 85	COLDMACHINE 86		
	Cooling capacities	250 litres max. normal refrigeration with direct evaporators, 70 litres max. deep-freezing		 SUITABLE FOR SOLAR OPERATION WITH CORROSION-RESISTANT STAINLESS STEEL MOUNTING PLATE	
	Voltage	12 / 24 V DC			
	Refrigerant	The cooling circuit contains the fluorinated greenhouse gas R 134a (45 g), CO ₂ equivalent: 0.064 t, GWP: 1430			
	System	Fully hermetic compressor with control electronics and integrated low-voltage protection, low-voltage cut-off, electronic reverse pole protection, brushless DC fan, fin condenser, self-sealing valve couplings			
	Dimensions (WxHxD)	386 x 160 x 130 mm	220 x 160 x 220 mm		220 x 230 x 177 mm
	Weight (kg)	6	6		6.5
	Quality features	Suitable for floor mounting, corrosion-resistant stainless steel mounting plate			
	Ref. No.	9105306597	9105306598		9105306599
	/ Optional extras				
	Mains adapter MPS 35, 110 – 240 V · 24 V				9600000445
Air exhaust hood with counterpart and 2 m hose, for providing air circulation			9103540107		

DOMETIC COLDMACHINE VD-03

FIN EVAPORATOR VD-03 FOR SERIES 80

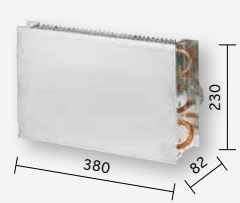
	Cooling capacities (l) with 35 mm PU insulation with 50 mm PU insulation	max. 170 max. 200	
	Power input (approx. watts)	50	
	Current consumption (Ah/h) with 35 mm PU insulation with 50 mm PU insulation	1.88 1.46	
	System	Copper-aluminium fin evaporator with large surface due to the cooling fins, for vertical and horizontal installation, self-sealing valve couplings, flexible connection pipe approx. 2.5 m, continuously variable thermostat (for external installation, with blue turning dial and LED indicator, white plastic housing), electric supply cord approx. 3 m	
	Dimensions (WxHxD)	380 x 230 x 82 mm	
	Weight (kg)	2	
	Ref. No.	9105306603	

DOMETIC COLDMACHINE VD-04

L-EVAPORATOR VD-04 FOR SERIES 80

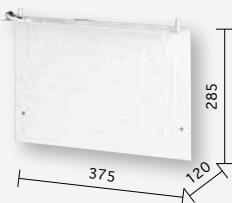
	Cooling capacities (l) with 35 mm PU insulation with 50 mm PU insulation	max. 130 max. 170
	Power input (approx. watts)	45
	Current consumption (Ah/h) with 35 mm PU insulation with 50 mm PU insulation	1.88 1.50
	System	Standard, L-shape evaporator, self-sealing valve couplings, flexible connection pipe approx. 2 m, continuously variable thermostat (for external installation, with blue turning dial and LED indicator, white plastic housing), electric supply cord approx. 3 m
	Dimensions (WxHxD)	375 x 285 x 120 mm
	Weight (kg)	1.5
	Ref. No.	9105306604

DOMETIC COLDMACHINE VD-05

PLATE EVAPORATOR VD-05 FOR SERIES 80

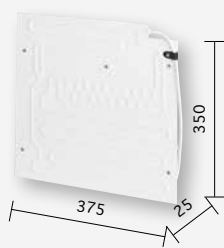
	Cooling capacities (l) with 35 mm PU insulation with 50 mm PU insulation	max. 130 max. 170
	Power input (approx. watts)	45
	Current consumption (Ah/h) with 35 mm PU insulation with 50 mm PU insulation	1.88 1.50
	System	Standard plate evaporator, self-sealing valve couplings, flexible connection pipe approx. 2 m, continuously variable thermostat (for external installation, with blue turning dial and LED indicator, white plastic housing), electric supply cord approx. 3 m
	Dimensions (WxHxD)	375 x 350 x 25 mm
	Weight (kg)	1.5
	Ref. No.	9105306605

DOMETIC COLDMACHINE VD-18

PLATE EVAPORATOR VD-18 FOR SERIES 80

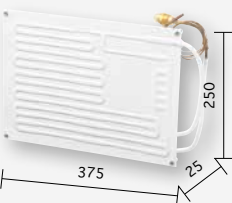
	Cooling capacities (l) with 35 mm PU insulation with 50 mm PU insulation	max. 100 max. 150
	Power input (approx. watts)	45
	Current consumption (Ah/h) with 35 mm PU insulation with 50 mm PU insulation	1.88 1.50
	System	Standard plate evaporator, self-sealing valve couplings, flexible connection pipe approx. 2 m, continuously variable thermostat (for external installation, with blue turning dial and LED indicator, white plastic housing), electric supply cord approx. 3 m
	Dimensions (WxHxD)	375 x 250 x 25 mm
	Weight (kg)	1.5
	Ref. No.	9105306614

DOMETIC COLDMACHINE VD-08

ANGLE EVAPORATOR VD-08 FOR SERIES 80

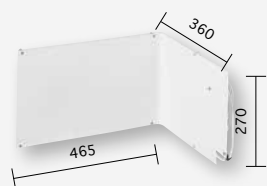

Cooling capacities (l) with 35 mm PU insulation with 50 mm PU insulation	max. 160
	max. 180
Power input (approx. watts)	60
Current consumption (Ah/h) with 35 mm PU insulation with 50 mm PU insulation	2.50
	2.00
System	Standard angle evaporator, self-sealing valve couplings, flexible connection pipe approx. 2 m, continuously variable thermostat (for external installation, with blue turning dial and LED indicator, white plastic housing), electric supply cord approx. 3 m
Dimensions (W x H x D)	465 x 270 x 360 mm
Weight (kg)	2.0
Ref. No.	9105306607

DOMETIC COLDMACHINE VD-09

O-EVAPORATOR VD-09 FOR SERIES 80



Cooling capacities (l) with 35 mm PU insulation with 50 mm PU insulation	max. 160
	max. 180
Power input (approx. watts)	60
Current consumption (Ah/h) with 35 mm PU insulation with 50 mm PU insulation	2.25
	1.75
System	O-evaporator for vertical and horizontal installation, self-sealing valve couplings, flexible connection pipe approx. 2 m, continuously variable thermostat (for external installation, with blue turning dial and LED indicator, white plastic housing), electric supply cord approx. 3 m
Dimensions (W x H x D)	365 x 141 x 270 mm
Weight (kg)	2.0
Ref. No.	9105306608



DOMETIC COLDMACHINE VD-15

CIRCULATING AIR EVAPORATOR VD-15 FOR SERIES 80

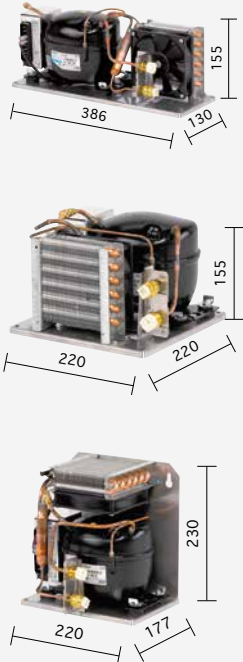

Cooling capacities (l) with 35 mm PU insulation with 50 mm PU insulation	max. 200
	max. 250
Power input (approx. watts)	60
Current consumption (Ah/h) with 35 mm PU insulation with 50 mm PU insulation	2.00
	1.50
System	High-performance circulating air evaporator in a white plastic housing, with brushless fan, fast cooling through circulating air operation, self-sealing valve couplings, flexible connection pipe approx. 2.5 m, continuously variable thermostat integrated in the evaporator housing
Dimensions (W x H x D)	220 x 275 x 80 mm
Weight (kg)	2.0
Ref. No.	9105306612

DOMETIC COLDMACHINE 94 / 95 / 96

COOLING UNITS	COLDMACHINE 94	COLDMACHINE 95	COLDMACHINE 96		
	Cooling capacities	400 litres max. normal refrigeration with direct evaporators, 250 litres max. with cold accumulators, 200 litres max. for deep-freezing		 SUITABLE FOR SOLAR OPERATION WITH CORROSION-RESISTANT STAINLESS STEEL MOUNTING PLATE ENERGY-SAVING AEO ELECTRONICS	
	Voltage	12 / 24 V DC			
	Refrigerant	The cooling circuit contains the fluorinated greenhouse gas R 134a (60 g), CO ₂ equivalent: 0.086 t, GWP: 1430			
	System	Fully hermetic high-performance compressor with AEO electronics and integrated low-voltage protection, low-voltage cut-off, electronic reverse pole protection, brushless DC fan, fin condenser, self-sealing valve couplings			
	Dimensions (WxHxD)	386 x 155 x 130 mm	220 x 155 x 220 mm		220 x 230 x 177 mm
	Weight (kg)	6	6		6.5
	Quality features	Suitable for floor mounting, corrosion-resistant stainless steel mounting plate, AEO electronics			
	Ref. No.	9105306600	9105306601		9105306602
	/ Optional extras				
	Mains adapter MPS 35, 110 – 240 V , 24 V				9600000445
Air exhaust hood with counterpart and 2 m hose, for providing air circulation			9103540107		

DOMETIC COLDMACHINE VD-14N

CIRCULATING AIR EVAPORATOR VD-14N FOR SERIES 90			
	Cooling capacities (l) with 35 mm PU insulation with 50 mm PU insulation		max. 300 max. 400
	Power input (approx. watts)		80
	Current consumption (Ah/h) with 35 mm PU insulation with 50 mm PU insulation		3.33 2.33
	System	High-performance circulating air evaporator, especially effective due to enlarged surface area. Radial fan with enhanced ventilation capacity, continuously variable room thermostat for optimal temperature distribution in the refrigeration compartment. Ease of installation with self-sealing valve couplings and flexible connection pipe (approx. 2.5 m). Sturdy, white plastic housing.	
	Dimensions (WxHxD)	250 x 310 x 90 mm	
	Weight (kg)	2.0	
	Ref. No.	9105306609	

DOMETIC COLDMACHINE VD-16

AIR CIRCULATING DEEP-FREEZE EVAPORATOR VD-16 FOR SERIES 90

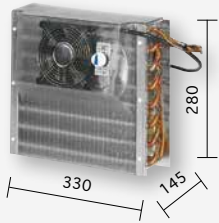

	Cooling capacities (l) with 50 mm PU insulation with 100 mm PU insulation	max. 130 max. 200
	Power input (approx. watts)	60
	Current consumption (Ah/h) with 50 mm PU insulation with 100 mm PU insulation	2.75 2.00
	System	High-performance air circulating fin evaporator in a transparent plastic housing, self-sealing valve couplings, flexible connection pipe approx. 2.5 m, continuously variable deep-freeze thermostat integrated in the evaporator housing
	Dimensions (W x H x D)	330 x 280 x 145 mm
	Weight (kg)	2.5
Ref. No.	9105306613	

DOMETIC COLDMACHINE VD-21

PLATE EVAPORATOR VD-21 FOR SERIES 90



	Cooling capacities (l) with 50 mm PU insulation with 100 mm PU insulation	max. 250 (normal refrigeration) / 100 (deep-freezing) max. 300 (normal refrigeration) / 150 (deep-freezing)
	Power input (approx. watts)	60
	Current consumption (Ah/h) with 50 mm PU insulation with 100 mm PU insulation	2.50 normal (refrigeration) / 3.00 (deep-freezing) 2.00 normal (refrigeration) / 2.00 (deep-freezing)
	System	Standard plate evaporator with large surface, self-sealing valve couplings, flexible connection pipe approx. 2 m, continuously variable thermostat (for external installation, with blue turning knob and LED indicator, white plastic housing), for refrigeration and deep-freezing
	Dimensions (W x H x D)	1373 x 305 x 10 mm
	Weight (kg)	4.0
Ref. No.	9105306615	

DOMETIC COLDMACHINE CS-NC15

COMPACT COOLING UNIT WITH STAINLESS STEEL GRILL AND HIGH-PERFORMANCE AIR CIRCULATING FIN EVAPORATOR

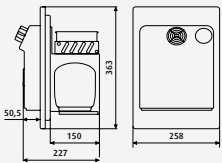

Cooling capacities (l) with 35 mm PU insulation with 50 mm PU insulation	max. 200 max. 250
Voltage	12 / 24 volts DC
System	Fully hermetic compressor with control electronics and integrated low-voltage protection, low-voltage cut-off, electronic reverse pole protection, brushless DC fan, fin condenser, high-performance air circulating fin evaporator in white plastic housing with brushless fan, rapid chill capability with circulating air operation
Refrigerant	The cooling circuit contains the fluorinated greenhouse gas R 134a (60 g), CO ₂ equivalent: 0.086 t, GWP: 1430
Current consumption (Ah/h) with 35 mm PU insulation with 50 mm PU insulation	2.00 1.50
Weight (kg)	8.5
Quality features	Rapid-chill capability with circulating air operation, continuously variable thermostat (integrated in the evaporator housing), low-voltage protection, low-voltage cut-off

CIRCULATING AIR EVAPORATOR FOR OPTIMAL COOLING PERFORMANCE AT MINIMAL ENERGY CONSUMPTION



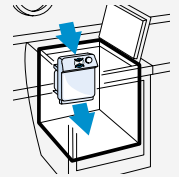



EASY TO INSTALL



Ref. No. 9105306593



	PRODUCT	VOLTAGE	REF. NO.	REF. NO. UK	PG	PAGE
 <p>Dometic Cool-Ice WCI 55</p>	Passive coolers					
	Portable boxes for cold and heat storage					
	Dometic Cool-Ice WCI 13	–	960000500	–	4.14	14
	Dometic Cool-Ice WCI 22	–	960000501	–	4.14	14
	Dometic Cool-Ice WCI 33	–	960000502	–	4.14	14
	Dometic Cool-Ice CI 42	–	960000541	–	4.14	14
	Dometic Cool-Ice CI 55	–	960000542	–	4.14	14
	Dometic Cool-Ice CI 70	–	960000543	–	4.14	14
	Dometic Cool-Ice CI 85	–	960000544	–	4.14	14
	Dometic Cool-Ice CI 85W	–	960000545	–	4.14	14
Dometic Cool-Ice CI 110	–	960000546	–	4.14	14	
 <p>Dometic TropiCool TCX 21</p>	Thermoelectric coolers					
	Portable thermoelectric coolers for refrigeration and heating					
	Dometic TropiCool TCX 14	12/24 V DC and 230 V AC	9103540486	9600010637	4.80	18
	Dometic TropiCool TCX 21	12/24 V DC and 230 V AC	9103540487	9600010638	4.80	19
Dometic TropiCool TCX 35	12/24 V DC and 230 V AC	9103540488	9600010639	4.80	19	
 <p>Dometic CoolFreeze CDF 18</p>	Compressor coolers					
	Portable compressor coolers for refrigeration and deep-freezing					
	Dometic CoolFreeze CDF 11	12/24 V DC	9103540285	–	4.80	25
	Dometic CoolFreeze CDF 18	12/24 V DC	9103540485	–	4.80	25
	Compressor coolers for refrigeration and deep-freezing with CFX special electronics					
	Dometic CoolFreeze CFX 35W	12/24 V DC, 100 – 240 V AC	9103540290	9600010568	4.80	27
	Dometic CoolFreeze CFX 40W	12/24 V DC, 100 – 240 V AC	9103540291	9600010569	4.80	28
	Dometic CoolFreeze CFX 50W	12/24 V DC, 100 – 240 V AC	9103540292	9600010602	4.80	28
	Dometic CoolFreeze CFX 65W	12/24 V DC, 100 – 240 V AC	9103540293	9600010603	4.80	29
	Dometic CoolFreeze CFX 100W	12/24 V DC, 100 – 240 V AC	9600002992	9600010636	4.80	29
 <p>Dometic CoolFreeze CFX 100W</p>	Heavy-duty cooling and deep-freeze containers					
	Dometic TL200	12 V DC / 230 V AC	9103540405	–	4.25	36
	Dometic TL300	12 V DC / 230 V AC	9600023549	–	4.25	36
	Dometic TL450	12 V DC / 230 V AC	9103540406	–	4.25	37
	Dometic FO200 NC	12 V DC / 230 V AC	9103540408	–	4.25	38
	Dometic FO450 NC	12 V DC / 230 V AC	9103540409	–	4.25	38
	Dometic FO650	12 V DC / 230 V AC	9600024342	–	4.25	40
	Dometic FO800 NC	12 V DC / 230 V AC	9600002642	–	4.25	40
	Dometic FO850	12 V DC / 230 V AC	9600024343	–	4.25	41
	Dometic FO1000 NC	12 V DC / 230 V AC	9600002641	–	4.25	41
 <p>Dometic TL450</p>	Medicine cabinets					
	Dometic DS 301 H	230 V AC	9600027080	9600027083	6.51	48
	Dometic DS 601 H	230 V AC	9600027074	–	6.51	48
	Dometic HC 302	230 V AC	9105204209	–	6.63	49
	Dometic HC 302D	230 V AC	9105204421	9105204423	6.63	49
	Dometic HC 502	230 V AC	9105204215	–	6.63	49
	Dometic HC 502D	230 V AC	9105204425	9105204427	6.63	49
 <p>Dometic DS 601 H</p>	Built-in heating cabinet					
	Dometic CoolMatic MH 07	12 V DC	9105204551	–	4.80	50

	PRODUCT	VOLTAGE	REF. NO.	REF. NO. UK	PG	PAGE
	Built-in compressor refrigerators					
	Dometic CoolMatic MR 07	12 V DC	9105204550	–	4.80	51
	Dometic CoolMatic MRR 07	12 V DC	9600000771	–	4.80	51
	Thermoelectric built-in cooler					
	Dometic TropiCool TB W203	12 V DC	9600000490	–	4.80	52
	Dometic TropiCool TB W203 HEATING	12 V DC	9103540147	–	4.80	52
	Compressor cooler drawer					
	Dometic CoolMatic CRD 50S	12/24 V DC	9103540374	–	6.51	53
	Milk coolers for automatic coffee machines					
	Dometic MyFridge MF 05M	100 – 240 V DC	9103500527	–	4.15	56
	Dometic MyFridge MF 1M	100 – 240 V DC	9103500526	–	4.15	56
	Dometic MyFridge MF 5M	230 V AC	9105301561	–	4.15	57
	Dometic DW 6	12 V DC / 230 V AC	9105330356	–	4.15	57
	Dometic Frigo cooling systems					
	Dometic Frigo DC 2500, R 134a		9600010782	–	2.04	62
	Dometic Frigo DC 3500, R 134a		9600010787	–	2.04	62
	Dometic adapter kit		vehicle-specific	–	2.04	63
	Dometic Frigo evaporator 2500, R 134a		8883000001	–	2.04	64
	Dometic Frigo evaporator 3500, R 134a		8883000003	–	2.04	64
	Dometic Frigo evaporator 4500, R 134a		8883000005	–	2.04	64
	Dometic Frigo condenser		vehicle-specific	–	2.04	65
	Dometic Frigo compressor		vehicle-specific	–	2.04	65
	Dometic Frigo stationary cooling		vehicle-specific	–	2.04	65
	Dometic Frigo hot-gas thawing		8883000404	–	2.04	65
	Cooling units					
	Dometic ColdMachine 54		9105306623	–	4.07	72
	Dometic ColdMachine 55		9105306624	–	4.07	72
	Dometic ColdMachine VD-01		9105306625	–	4.07	72
	Dometic ColdMachine VD-02		9105306627	–	4.07	73
	Dometic ColdMachine VD-07		9105306625	–	4.07	73
	Dometic ColdMachine 84		9105306597	–	4.07	74
	Dometic ColdMachine 85		9105306598	–	4.07	74
	Dometic ColdMachine 86		9105306599	–	4.07	74
	Dometic ColdMachine VD-03		9105306603	–	4.07	74
	Dometic ColdMachine VD-04		9105306604	–	4.07	75
	Dometic ColdMachine VD-05		9105306605	–	4.07	75
	Dometic ColdMachine VD-18		9105306614	–	4.07	75
	Dometic ColdMachine VD-08		9105306607	–	4.07	76
	Dometic ColdMachine VD-09		9105306608	–	4.07	76
	Dometic ColdMachine VD-15		9105306612	–	4.07	76
	Dometic ColdMachine 94		9105306600	–	4.07	77
	Dometic ColdMachine 95		9105306601	–	4.07	77
	Dometic ColdMachine 96		9105306602	–	4.07	77
	Dometic ColdMachine VD-14N		9105306609	–	4.07	77
	Dometic ColdMachine VD-16		9105306613	–	4.07	78
Dometic ColdMachine VD-21		9105306615	–	4.07	78	
Dometic ColdMachine CS-NC15		9105306593	–	4.07	79	



Dometic is a global company that makes mobile living easy – by providing great solutions to satisfy people’s essential needs when they are on the move. Like cooking, taking care of personal hygiene and maintaining a pleasant temperature. We offer smart and reliable products with outstanding design.





Mobile living made easy.



AUSTRALIA

DOMETIC AUSTRALIA PTY. LTD.

1 John Duncan Court
Varsity Lakes QLD 4227
Tel +61 7 55076000
Fax +61 7 55076001
Mail sales@dometic-waeco.com.au

AUSTRIA & CZECH REPUBLIC

DOMETIC AUSTRIA GMBH

Neudorferstrasse 108
A-2353 Guntramsdorf
Tel +43 2236 908070
Fax +43 2236 90807060
Mail info@dometic.at

BELGIUM

DOMETIC BRANCH OFFICE BELGIUM

Lourdesstraat 84 B
B-8940 Geluwe
Tel +32 2 3598040
Fax +32 2 3598050
Mail info@dometic.be

DENMARK

DOMETIC DENMARK A/S

Nordensvej 15, Taulov
DK-7000 Fredericia
Tel +45 75585966
Fax +45 75586307
Mail info@dometic.dk

FINLAND

DOMETIC FINLAND OY

Valimotie 15
FIN-00380 Helsinki
Tel +358 20 7413220
Mail info@dometic.fi

FRANCE

DOMETIC SAS

ZA du Pré de la Dame Jeanne
B.P. 5
F-60128 Plailly
Tel +33 3 44633525
Fax +33 3 44633518
Mail automotive@dometic.fr

GERMANY

DOMETIC GERMANY GMBH

Hollefeldstraße 63
D-48282 Emsdetten
Tel +49 (0) 2572 879-0
Fax +49 (0) 2572 879-300
Mail info@dometic-waeco.de

HONG KONG

DOMETIC GROUP ASIA PACIFIC

Suites 2207-2210, 22/F Tower 1
The Gateway, 25 Canton Road
Tsim Sha Tsui, Kowloon
Tel +852 2456 5199
Fax +852 2466 5553
Email info.ap@dometic.com

HUNGARY

DOMETIC ZRT. SALES OFFICE

H-1147 Budapest
Kerekgyártó u. 5.
Tel +36 1 468 4400
Fax +36 1 468 4401
Mail budapest@dometic.hu

ITALY

DOMETIC ITALY S.R.L.

Via Virgilio, 3
I-47122 Forlì (FC)
Tel +39 0543 754901
Fax +39 0543 754983
Mail vendite@dometic.it

JAPAN

DOMETIC KK

Maekawa-Shibaura, Bldg. 2
2-13-9 Shibaura Minato-ku
Tokyo 108-0023
Tel +81 3 5445 3333
Fax +81 3 5445 3339
Mail info@dometic.jp

MEXICO

DOMETIC MX, S. DE R. L. DE C. V.

Circuito Médicos No. 6 Local 1
Colonia Ciudad Satélite
CP 53100 Naucalpan de Juárez
Estado de México
Tel +52 55 5374 4108
Fax +52 55 5393 4683
Mail info@dometic.com.mx

NETHERLANDS

DOMETIC BENELUX B.V.

Ecustraat 3
NL-4879 NP Etten-Leur
Tel +31 76 5029000
Fax +31 76 5029019
Mail info@dometic.nl

NEW ZEALAND

DOMETIC NEW ZEALAND LTD.

PO Box 12011
Penrose
Auckland 1642
Tel +64 9 622 1490
Fax +64 9 622 1573
Mail customerservices@dometic.co.nz

NORWAY

DOMETIC NORWAY AS

Elveveien 30B
N - 3262 Larvik
Tel +47 33428450
Fax +47 33428459
Mail info@dometic.no

POLAND

DOMETIC POLAND SP. Z O.O

ul. Puławska 435A
PL-02-801 Warszawa
Tel +48 22 414 3200
Fax +48 22 414 3201
Mail info@dometic.pl

PORTUGAL

DOMETIC SPAIN, S.L.

Branch Office em Portugal
Rot. de São Gonçalo nº 1 – Esc. 12
2775-399 Carcavelos
Tel +351 219 244 173
Fax +351 219 243 206
Mail info@dometic.pt

RUSSIA

DOMETIC RUS LLC

Komsomolskaya square 6 – 1
RU-107140 Moscow
Tel +7 495 780 79 39
Fax +7 495 916 56 53
Mail info@dometic.ru

SINGAPORE

DOMETIC PTE LTD

18 Boon Lay Way
06-141 Trade Hub 21
Singapore 609966
Tel +65 6795 3177
Fax +65 6862 6620
Mail dometic@dometic.com.sg

SLOVAKIA

DOMETIC SLOVAKIA S.R.O.

Sales Office Bratislava
Nádražná 34/A
900 28 Ivánka pri Dunaji
Tel +421 2 45 529 680
Fax +421 2 45 529 680
Mail bratislava@dometic.com

SOUTH AFRICA

DOMETIC (PTY) LTD.

Regional Office South Africa &
Sub-Saharan Africa
2 Avalon Road, West Lake View
Ext 11, Modderfontein 1645
Tel +27 87 3530380
Mail info@dometic.co.za

SPAIN

DOMETIC SPAIN, S.L.

Avda. Sierra del Guadarrama, 16
E-28691 Villanueva de la Cañada
Madrid
Tel +34 91 833 60 89
Fax +34 900 100 245
Mail info@dometic.es

SWEDEN

DOMETIC SCANDINAVIA AB

Gustaf Melins gata 7
SE-421 31 Västra Frölunda
Tel +46 31 7341100
Fax +46 31 7341101
Mail info@dometicgroup.se

SWITZERLAND

DOMETIC SWITZERLAND AG

Riedackerstrasse 7a
CH-8153 Rümlang
Tel +41 44 8187171
Fax +41 44 8187191
Mail info@dometic.ch

UNITED ARAB EMIRATES

DOMETIC MIDDLE EAST FZCO

P.O. Box 17860
S-D 6, Jebel Ali Freezone
Dubai
Tel +971 4 883 3858
Fax +971 4 883 3868
Mail info@dometic.ae

UNITED KINGDOM

DOMETIC UK LTD.

Domestic House, The Brewery,
Blandford St. Mary
Dorset DT11 9LS
Tel +44 344 626 0133
Fax +44 344 626 0143
Mail info@dometic.co.uk

UNITED KINGDOM

DOMETIC UK AWNINGS LTD

Little Braxted Hall,
Little Braxted, Witham,
Tel +44 1376 500111
Fax +44 1376 500115
Mail in.orders.kampa@dometic.com

USA

DOMETIC RV DIVISION

1120 North Main Street
Elkhart, IN 46515
Tel +1 574-264-2131

WE DISTRIBUTE OUR PRODUCTS IN AROUND 100 MARKETS. PLEASE ASK FOR YOUR CONTACT POINT IF NOT LISTED HERE OR CHECK THE WEB.

DOMETIC.COM